

S L I D E R

User Manual  
Metro E3

slider.eu

# Welcome to the SLIDER!

Thank you for purchasing the METRO E3 from SLIDER!

We take pride in bringing you a quality product that will offer years of enjoyment. Please read and understand this manual fully before assembling and riding your bike; the latest version of your manual is available at [www.slider.eu](http://www.slider.eu). And be sure to watch the official SLIDER assembly video available at [www.slider.eu](http://www.slider.eu) or at the QR code shown here.



Additional information about your SLIDER can be found in our Help Centre at [www.slider.eu](http://www.slider.eu).

Be sure to check all hardware for correct (see “Unboxing”) during assembly. Before each ride, follow the recommendations in the Safety check in manual. Finally, take care of your new SLIDER by following the guidelines in “Maintenance”. If you’re not sure you have the skills, experience, and special tools required for assembly and maintenance, get help from a local, certified, and reputable bike mechanic.

## WE ARE HERE TO HELP!

If you have questions after reading this manual and watching the assembly video, please consult the SLIDER Help Centre, contact us by email, and/or give us a call on the phone. Thanks for riding SLIDER!

SLIDER Help Centre : [www.slider.eu](http://www.slider.eu)

E-mail : [contact@slider.eu](mailto:contact@slider.eu)

Phone : +35-9897494937

# SLIDER METRO E3 Folding Electric Bike User Manual

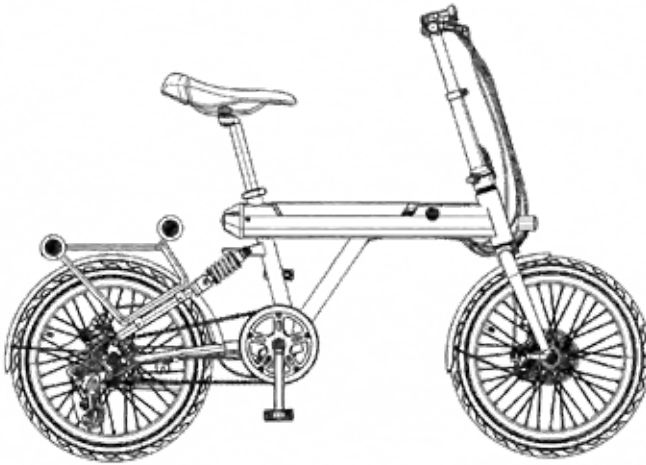

## Table of content

1. Precautions.....	03
2. Assembly Instructions.....	04
3. Assembly Step Instructions and Precautions.....	05-17
4. Battery Precautions.....	18-27
5. function test.....	28-30
5. Precautions for use.....	31-38
6. maintainance.....	39
7. safety checklists.....	40-62
8. warranty.....	63-65

# Using this manual

This manual contains critical details about how to safely operate and maintain your SLIDER. Read it carefully and familiarize yourself with your ebike before riding it. Pay special attention to the safety messages shown here.



**NOTICE:** A “notice” is important information that can help you avoid bike/property damage or extend the life of parts and the bike.



**CAUTION:** A “caution” statement indicates a hazardous situation that, if not avoided, could result in minor or moderate injury or property damage.



A “warning” statement indicates a hazardous situation that, if not avoided, could result in death, serious injury, or property damage.



A “danger” statement indicates a hazardous situation that, if not avoided, has a very high risk of death, serious injury, or property damage.

Riding any bike or other vehicle always involves some risk of serious injury or death. Your safety depends on many factors including your bike knowledge, your bike’s maintenance, foreseeable riding conditions, etc. There are also factors we cannot control or anticipate in every situation or condition while riding. This manual makes no representations about the safe use of bikes under all conditions. If you have any questions you should contact SLIDER immediately.

Assembly and first adjustment of your bike from SLIDER requires special tools and skills. We recommend that you have this done by a certified, reputable bike mechanic. Keep this manual and any other documents that came with your BIKE. All content in this manual is subject to change or withdrawal without notice. Visit [www.slider.eu](http://www.slider.eu) to view and download the latest version. SLIDER bikes makes every effort to ensure the accuracy of its documentation and assumes no responsibility or liability if any errors or inaccuracies appear within.

# Assembly instructions for the SLIDER

The following steps provide an overview of how to assemble your METRO E3 from SLIDER. They are not a complete or comprehensive manual of all aspects of assembly, maintenance, and repair, which involve specialized tools and skills. We recommend you consult a certified, reputable bike mechanic to assist in the assembly, repair, and maintenance of your SLIDER.

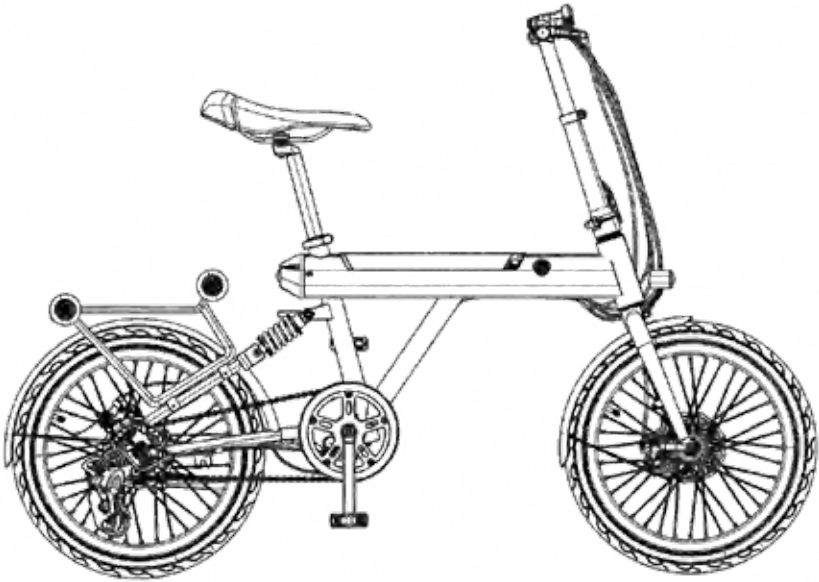

Fully assembled SLIDER METRO E3 FOLDING E-BIKE

Please note that your SLIDER may include components that look different from those in the illustrations above and elsewhere in this manual. Such changes help ensure uninterrupted shipping. Our engineers rigorously test each component to guarantee quality and compatibility.

**⚠ WARNING:** Incorrect assembly, maintenance, or use of your ebike can cause component or performance failure, loss of control, serious injury, or death. Even if you're an experienced bike rider, you must read and understand the entire manual and any documentation provided for subcomponents or accessories before riding. If you are not sure you have the experience, skills, and tools to correctly perform all assembly steps in the manual and the assembly video at [www.slider.eu](http://www.slider.eu), consult a local, certified, reputable bike mechanic.

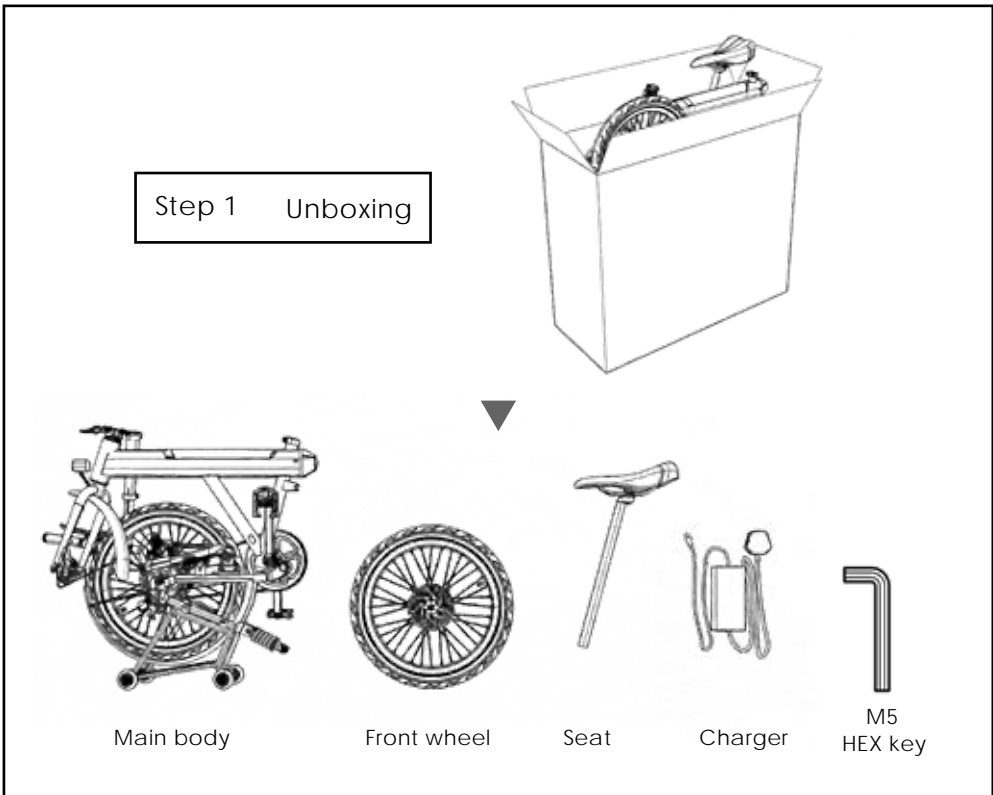

Check if the contents are complete

1. Unboxing the bike. Open the bike box with the help of another person capable of safely lifting a heavy object, remove the ebike from the bike box, placing it upright on the back wheel and front fork protector plate. Carefully remove the packaging material protecting the bike frame and components, and keep the packaging materials in case you want to ship the bike. Otherwise, recycle these materials, especially cardboard and foam, wherever possible. Remove the small box from the bottom of the bike box and carefully set out the contents. Ensure all of the following pieces are included with the ebike like picture.

If anything is missing, please contact SLIDER.  
We also recommend the following (not included) for assembly and maintenance:

- A strong friend
- Flat-side cutters
- 15 mm pedal wrench
- Bicycle grease
- Clean shop towel or paper towel for cleaning excess grease
- Bike pump with Schrader valve and pressure gauge
- Torque wrench (3 Nm-60 Nm) with Allen bits

Step 2 Fixed Folding Tube

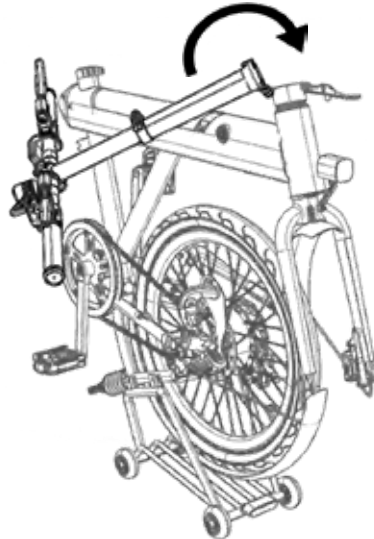

2. After taking out the bicycle and checking that there is no problem, first rotate and fix the handlebar of the bike as shown in the picture. Please be sure to lock the handlebar tightly. If you find that it cannot be fixed or the tenon is damaged, please contact us and we will serve you. In addition, please use the Allen wrench to confirm that all the screws on the handlebar have been tightened. If you find any untightened screws or other problems, please contact our customer service to avoid accidents when riding. cause danger.

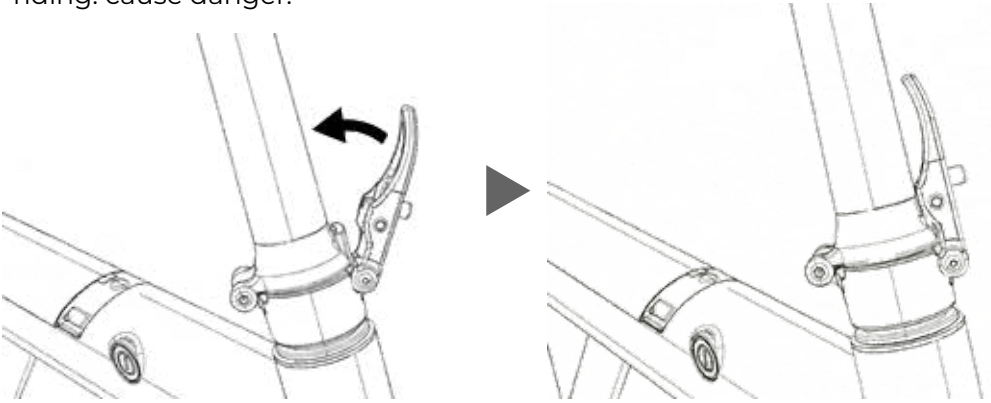

Make sure the folding tube is locked



Caution: Must be lock tide before riding !

Step 3 Frame Expand

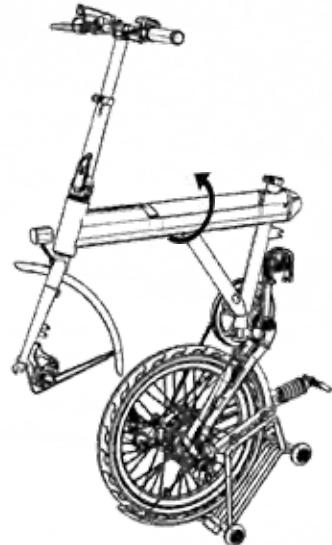



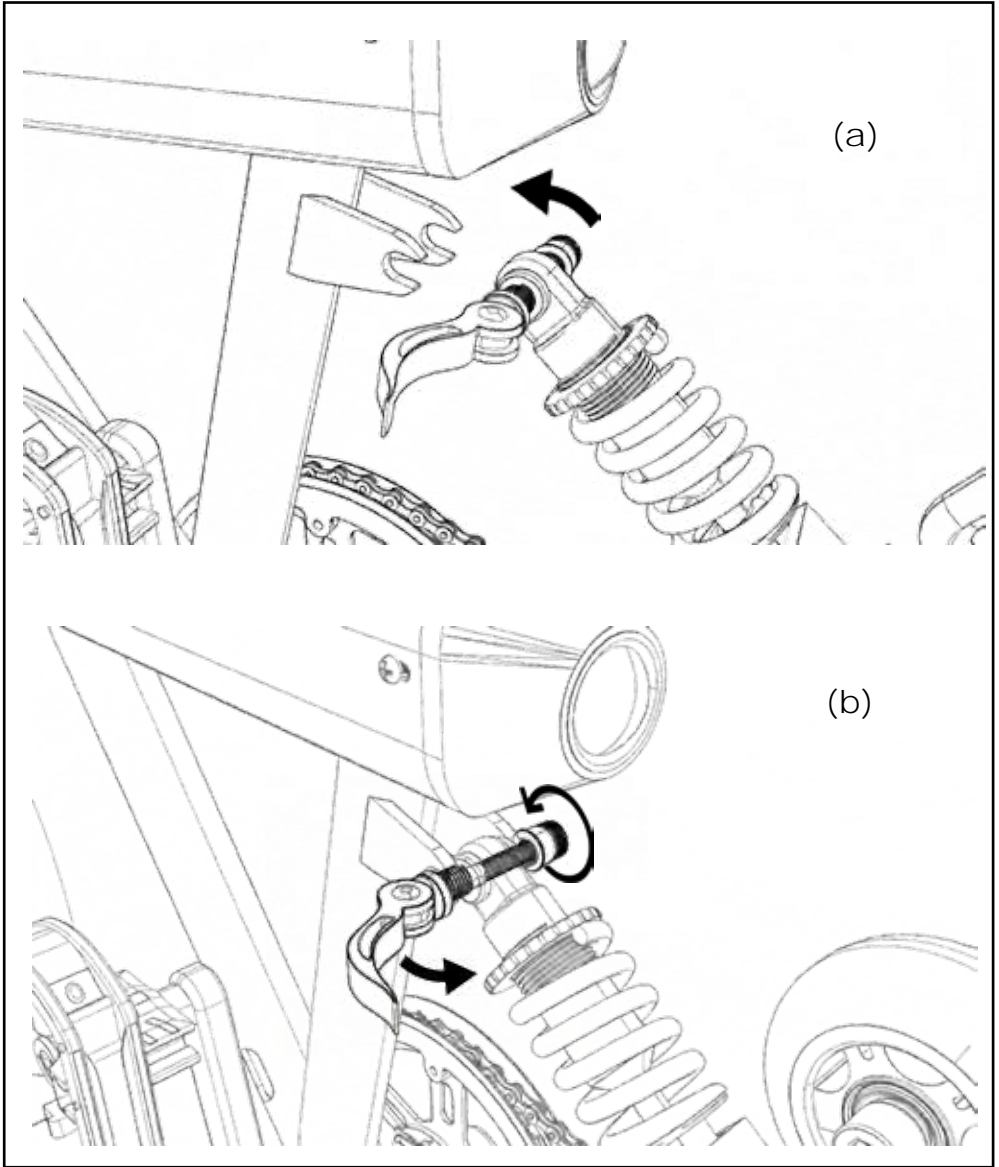

3. Work with your strong friend to unfold the folded bicycle to the riding state, and follow the above steps to lock it.

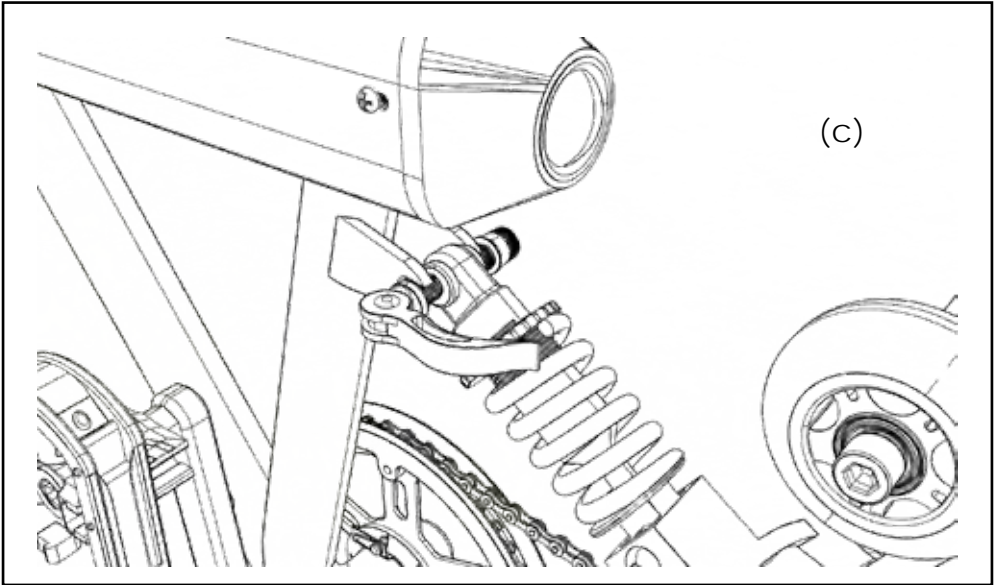

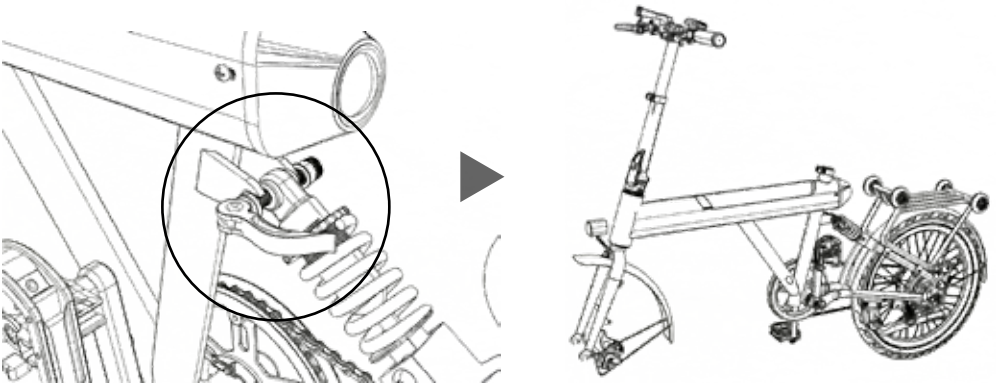

(a) After unfolding, align the shock absorber tenon on the rear fork with the frame buckle and insert it, (b) and turn the screw on the quick release kit to lock it to tightly be like (c).



 Caution: Must be lock tide before riding !

Step 4 Install Front Wheel

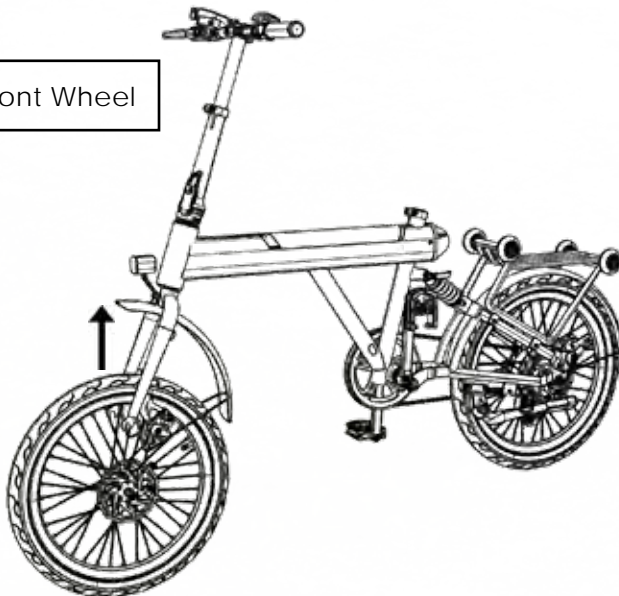

4. Hold the quick-release lever in line with the axle and tighten the thumbnut until the lever can stay parallel to the floor without being held. Use the palm of your hand to close the lever fully, without touching the brake rotor. The quick-release lever secures the front wheel to the bike, so it's important that the thumbnut is tight enough that the closed lever has adequate clamping force to keep the axle and wheel firmly in place. When you close the lever, there should be enough resistance that it leaves an imprint in your hand.

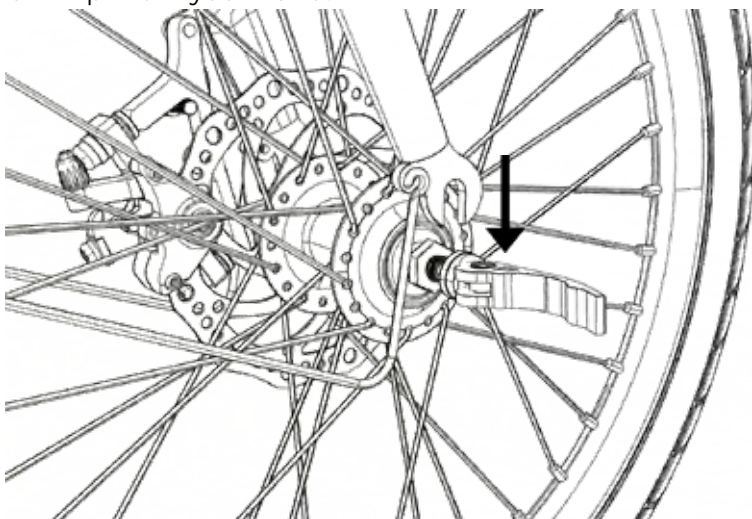

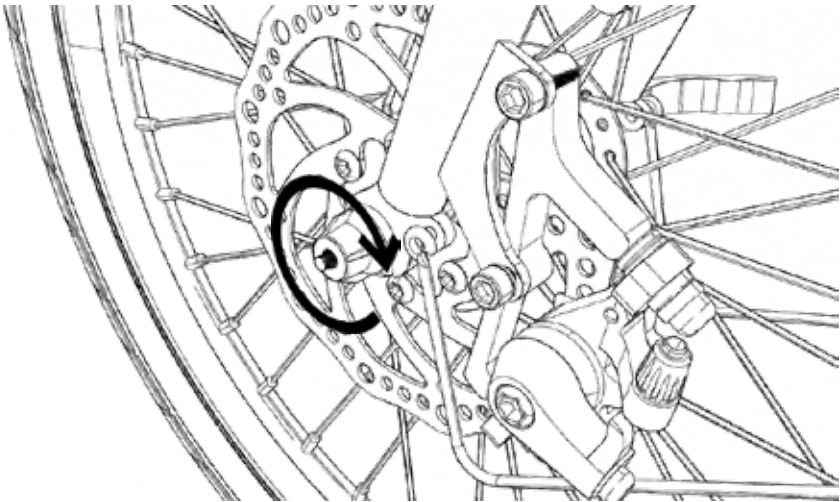
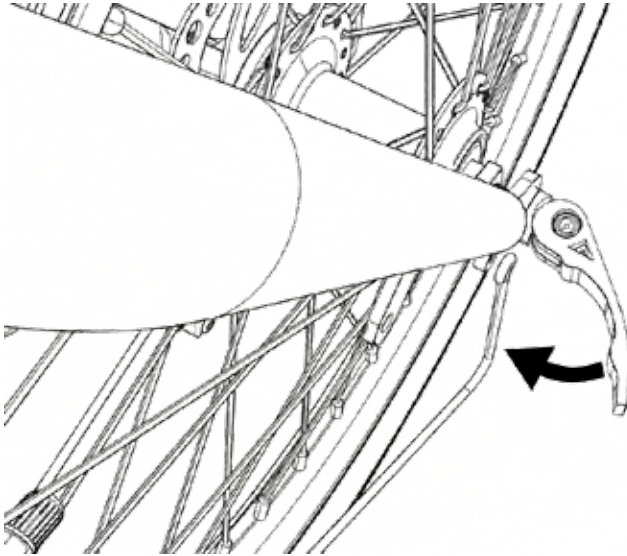

After confirming that the direction is consistent, first loosen the quick release screw (but do not disassemble it), align the hole on the front fork and install the wheel, and then tighten the quick release screw after confirming that the direction of the wheel and the front fork is not offset, and Tighten the quick release kit.



Caution: Front wheel Must be lock tide before riding !

Check the security of the front wheel and quick-release lever. If it's too easy or too difficult to close, adjust the lever tension by turning the thumbnut one turn, then close the lever. Check the front wheel security on a regular basis: the front wheel should always be fully seated in the dropouts of the front fork, and the quick-release lever should always be properly secured.

Check the security of the rear wheel. The rear wheel security and hardware torque should also be checked on a regular basis. Either wheel can become loose or unsecured with normal use.

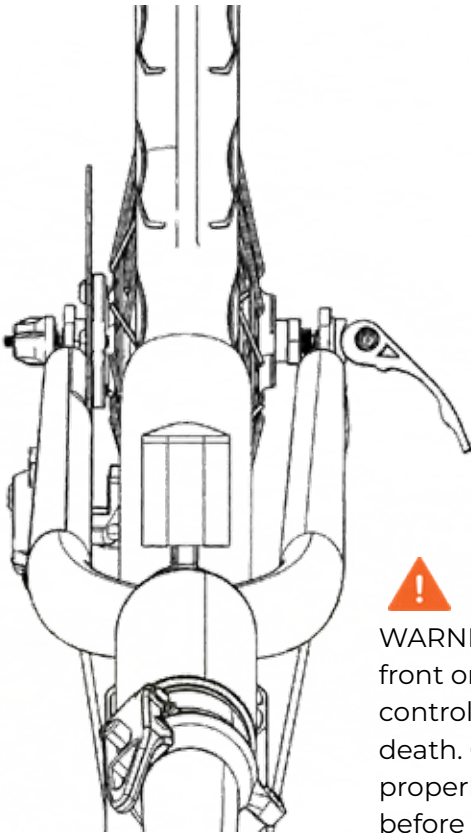

 **WARNING:** An improperly secured front or rear wheel can cause loss of control, accidents, serious injury, or death. Check that both wheels are properly secured during assembly and before each ride.

Step 5 Rotate Padel

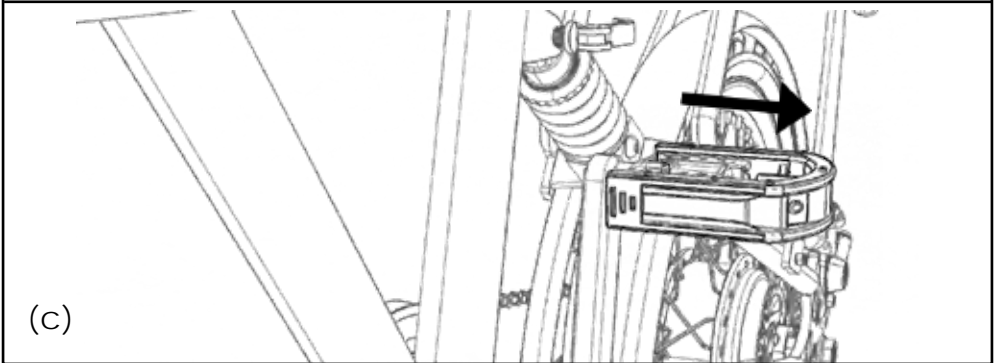
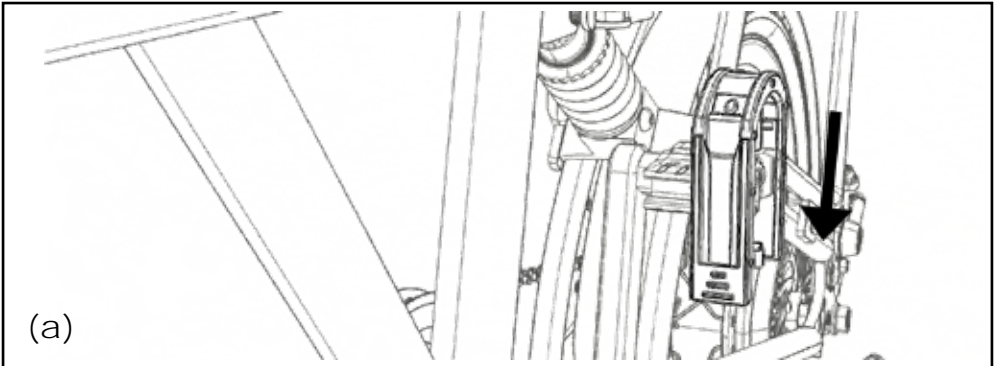

- (a) Press down on the pedals in the folded state to align the inner rotating structure
- (b) Rotate the pedals to position as in the above picture
- (c) After rotating to the position, the pedal will automatically rebound and fix

## Step 6 Install Seat

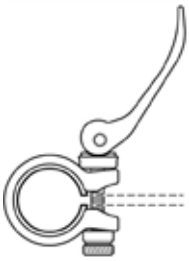

1

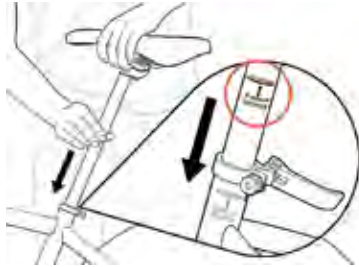

2

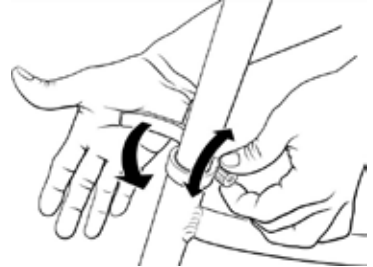

3

1. Open the seatpost quick-release lever.
2. Slide the seatpost in or out of the seat tube to a height appropriate for your leg length and preference. Do not extend the seatpost beyond the minimum insertion marking etched onto the seatpost (see the “Seat post out TOO FAR” illustration).
3. Align the quick release clamp opening with the notch in the seat tube, and close the quick-release lever fully. Closing the lever should require enough pressure that it leaves an imprint in your hand. When closed, the seat should not move up, down, left, or right. If needed, adjust the lever tension by turning the adjustment nut opposite the quick-release lever.
4. Try out your seat fit, and repeat steps 1–3 if the seat position needs a bit more adjusting.



**DANGER:** Overextending the seatpost can cause it to break or fall off your bike, which will put you at very high risk of serious injury or death. Avoid this danger by inserting your seatpost into the seat tube far enough that the minimum insertion point is no longer visible.

# Adjusting for comfort and safety

The following steps are critical for your comfort and safety, and must be performed before your first bike ride. We recommend that you consult a bike fitting professional such as a certified, reputable bike mechanic who specializes in bike fit.

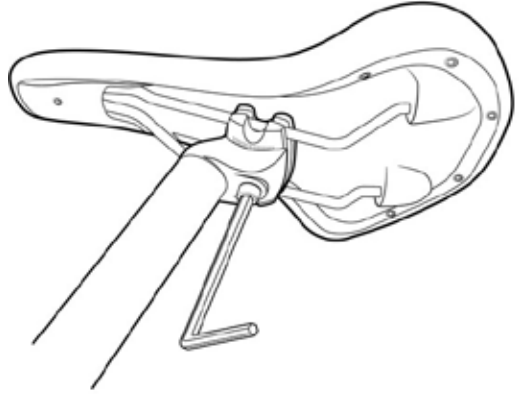

## Adjusting the seat angle and horizontal position

Many riders will prefer the seat to be roughly parallel to the ground, with its horizontal position in the middle of the range marked on the seat rails. To change the angle and horizontal position of the seat:

1. Use a 6 mm Allen wrench to loosen (but do not remove) the seat adjustment bolt on the clamp located underneath the seat.
2. Move the seat backwards or forwards and tilt to adjust the angle. Do not exceed the limit markings etched into one of the seat rails, which show how far you can safely move the seat forwards and backwards.
3. Ensure the top of the seat rail clamp is aligned directly over the bottom of the clamp so that the seat adjustment bolt will clamp the seat rails properly. Then, while holding the seat in the desired position, use a 6 mm Allen wrench to tighten the seat adjustment bolt securely to the torque value.



**WARNING:** A loose seat clamp or seat adjustment bolt can cause loss of control, bike/property damage, serious injury, or death. Prior to first use, be sure to tighten the seat clamp via the seat adjustment bolt properly. Regularly check to make sure that the seat adjustment bolt is properly tightened and the clamp is secure on the seat rails.



# Adjusting the seat height

An ideal seat height for most riders allows them to be comfortable and get the best pedalling efficiency. When the rider is seated, they should be able to place the ball of their foot on the pedal at its lowest position while their leg is almost fully extended, with the knee slightly bent. The seat should never be so high that the rider must rock side to side or fully straighten their legs while pedalling. And the seat must never be pulled out so far that the minimum insertion point is above the seat tube.



Depending on a rider's preference, ability, and amount of experience with bike and ebike riding, lowering the seat so the rider can put one or both feet on the ground without dismounting from the seat may offer a safer and more comfortable experience while operating the bike.

---

## Tools and recommended torque values

The tool sizing listed below is a general guide, but it is possible that the head of a particular bolt on your bike may vary, requiring a different tool (e.g., a 4 mm Allen wrench instead of a 5 mm Allen wrench). If so, use whatever tool fits the bolt head. Such differences will not affect the recommended torque for that piece of hardware.

		Tool	Rec. torque
<b>Handlebar area</b>	Stem clamp bolts	5 mm Allen	10 Nm
	Stem faceplate bolts	5 mm Allen	6 Nm
	Stem angle adjustment bolt ( <b>side</b> )	5 mm Allen	12 Nm
	Stem angle adjustment bolt ( <b>bottom</b> )	5 mm Allen	15 Nm
	Rad UI Display clamp bolts	3 mm Allen	3 Nm
	Rad UI Remote clamp bolt	3 mm Allen	3 Nm
	Shifter clamp bolt	Phillips or flat head	6 Nm
	Brake lever clamp bolts	5 mm Allen	6 Nm
<b>Brake area</b>	Calliper adapter to frame	5 mm Allen	6–8 Nm
	Calliper to adapter	5 mm Allen	6–8 Nm
	Brake pads to calliper	Cotter pin	n/a
	Brake rotor to hub	T25 Torx bit	7 Nm
<b>Seat area</b>	Seat adjustment bolt	6 mm Allen	15 Nm
<b>Frame downtube</b>	Controller mounting bolts	3 mm Allen	3 Nm
	Frame cable cover bolts	2.5 mm Allen	tighten securely; do not overtighten
<b>Rear dropout area</b>	Rear axle nuts	18 mm wrench	40 Nm
	Torque arm bolt	4 mm Allen	5 Nm
	Derailleur hanger mounting bolt	5 mm Allen	10 Nm
	Derailleur mounting bolt	5 mm Allen	10 Nm
	Derailleur cable clamp bolt	5 mm Allen	6–8 Nm
<b>Bottom bracket and crank area</b>	Pedal into crank arm	15 mm pedal wrench	35 Nm
	Crank arm removal info	Crank puller for square taper bottom bracket	n/a
	Crank arm bolt into bottom bracket spindle	8 mm Allen	35 Nm
	Freewheel removal information	Contact Rad Power Bikes Product Support	n/a
	Chainring bolts	5 mm Allen	10 Nm
	Kickstand mounting bolts	5 mm Allen	8 Nm
	Bottom bracket and cups	BBT-22 Park Tool	60 Nm
	<b>Accessories</b>	Headlight/front fender/mudguard mounting bolt	5 mm Allen and 10 mm wrench

## Step 7 Battery Charging

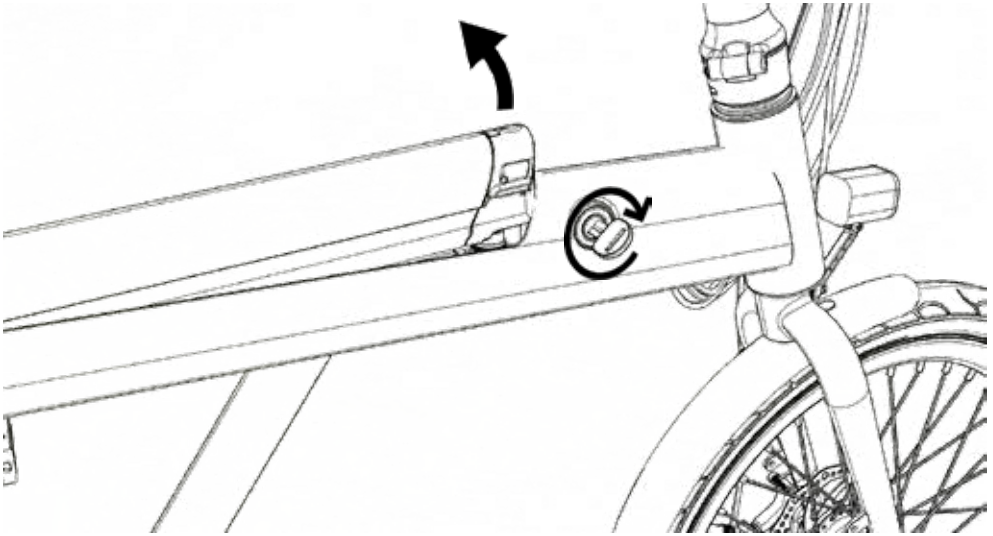

Insert the key to unlock the battery

It is possible to remove the battery for storage, transportation, security, or as an option for charging. To remove the battery, follow these steps.

1. Place the key into the keyport and turn it to the unlocked position.
2. The battery lock will release the battery from the frame and lift it out of the mount slightly.
3. Carefully lift the battery up, angling it away from and clearing the terminal contacts ("3" in the illustration above).
4. Pull the battery out of the mount. Be careful not to drop or damage the battery when it's loose from the bike. Do not touch or bend the terminal contacts.

## CHECK CHARGE LEVEL

Please check the color of the indicator light on the charger. If it is red, it means it is not fully charged. If the indicator light on the charger turns green or turns off, it means the battery is fully charged.

## Critical battery safety overview

- Protect the battery from impact damage. Do not drop the battery. Ensure the battery is locked to the frame before riding.
- Protect the battery from water and corrosion damage. Never submerge the battery in water. Allow rain to run off of the battery from top to bottom as designed. Avoid salt water and deicing compounds, which are very corrosive and can lead to damage and danger.
- Remove the key from the bike's battery keyport before riding.
- Never open the battery housing or charger. There are no user-serviceable parts in either the battery or battery charger.
- Turn off the bike for maintenance. Before performing any bike maintenance, bike cleaning, or part replacement, power off the bike and remove the battery to prevent accidental motor activation. Also discharge any remaining power in the electrical system by pressing the power button. That will protect all of the electrical components.

## TEMPERATURES FOR SAFE STORAGE, CHARGING, AND USE

For safety and the best battery performance, please be aware of the following:

- Avoid riding in extreme temperatures, above 45°C (113°F), whenever possible.
- If you ride in extremely hot temperatures (above 45°C (113°F)), use low levels of power assistance to keep the battery as cool as possible. This will lower the risk of the battery automatically turning off to prevent use-caused heat damage.
- Heat can cause the battery to automatically turn off.
- When the battery temperature reaches more than 60°C (140°F), the battery is designed to turn off automatically to prevent use-caused heat damage. When the battery cools enough, you should be able to turn your battery back on.

- Charging your battery when it is warm from riding or from ambient temperatures more than 45°C (113°F) can cause the battery and charger to power off as a safety precaution.
- Extreme heat can cause permanent battery damage.
- Prolonged storage temperatures that exceed 45°C (113°F) can reduce the useful life of the battery.
- Using your battery so that its temperature reaches 45°C (113°F) or higher may cause permanent damage to the battery in the form of decreased range per charge for the remainder of the battery's useful life.
- Storing your battery at temperatures higher than 60°C (140°F) (such as in a hot car in the direct sunlight) may cause permanent range decline or critical failure up to and including an electrical fire.
- Cold can reduce battery range temporarily. Riding in temperatures lower than 0°C (32°F) may significantly reduce riding range for that ride. Do not depend on the battery power to perform for the same range available above 0°C (32°F).
- Extreme cold can cause the battery to automatically turn off. At -20°C (-4°F) the battery will shut off to prevent damage. Do not depend on battery power to return you back to safety if riding near those extreme temperatures.

## TEMPERATURE RANGE SUMMARY

These are the maximum safe and recommended temperature ranges for your SLIDER battery. Please see the preceding section for more information.

Maximum use range: -20°C to 49°C (-4°F to 120°F)

Maximum charging range: 0°C to 45°C (32°F to 113°F)

Recommended charging range: 10°C to 25°C (50°F to 77°F)

Maximum storage range: -20°C to 60°C (-4°F to 140°F)

## Charging the battery

- Always charge your battery with the charger supplied by SLIDER.
- Check that the battery and charger are undamaged before charging. If the battery or charger look damaged or were involved in a fall or crash (even without outward or obvious signs of damage) contact SLIDER Bikes Product Support for more information.
- Charge your battery in a temperature controlled, dry, safe location ideally at room temperature, 10°C to 25°C (50°F to 77°F). Always charge between 0°C to 45°C (32°F to 113°F), because charging outside of this range may cause permanent damage to the battery in the form of decreased range per charge for the remainder of the battery's useful life.
- Use the charger in a safe place—away from children, direct sunlight, dirt, debris, liquids, tripping hazards (including electrical cords), or any materials that could ignite in the unlikely event of a charger or battery malfunction. Position the charger and battery where they're safe and not at risk for falls or other impacts.
- Your battery and charger generate heat while charging, but they're designed to air-cool. While charging, keep them uncovered on a flat, stable, hard surface. Your charger should face upward with its light visible when in use.
- Store the charger unplugged in a safe place—away from children, direct sunlight, in a place where it could fall, etc. Make sure the charger plugs do not come in contact with liquids, dirt, debris, or metal objects, which can damage the plug and interfere with future operation.

**TIP!** Charge an empty battery as soon as possible. If the battery is completely empty, charge it as soon as possible. Storing a depleted (empty) battery can lead to permanent loss of range or loss of battery life.

**TIP!** Recharge the battery after each ride. Always charge it back to full so it is ready to go the full range per charge next time you want to ride.

# CHARGING PROCEDURE

Anytime you charge your battery, check the battery, charger, and electrical cables for signs of damage. Follow the steps below.

- 1.Ensure the bike is off. Press and hold the power button on the UI Remote until the display turns off. If desired, use the key to unlock and remove the battery from the bike frame. The battery can be charged while it is on or off the bike.
- 2.Inspect the battery, charger, and electrical cables for damage. If everything looks fine, proceed with the rest of the steps. If you find any damage, don't charge your bike. Instead, take photos and seek more information from our Help Centre at [www.slider.eu](http://www.slider.eu) or by contacting SLIDER Product Support.
- 3.Plug the charger into the battery's charging port. Place the charger on a flat, secure surface with the charging status light facing up, open the rubber cover on the battery's charging port, and connect the DC output plug from the charger (round barrel connector) to the charging port on the side of the battery.
- 4.Plug the charger into a power outlet. Connect the charger input plug (110/220-volt plug) to the power outlet. Charging should initiate and will be indicated by the charger status light on the charger turning red.
- 5.Unplug the charger from the outlet, then the charging port. Once fully charged, indicated by the charger status light turning green, disconnect the charger from the outlet then the charger from the battery by pulling directly on the plugs, not the wires themselves.

**NOTICE:** The charger is designed to stop charging automatically when the battery is fully charged. Nevertheless, we recommend you disconnect the battery from the power source and charger as soon as possible once charging is complete. As with any appliance, you should unplug your charger when you're not using it to charge your battery. This will also prevent range decline from unnecessary charging.

# ESTIMATED CHARGING TIMES

The time the charger takes to fully charge the battery depends on factors including distance travelled, riding characteristics, terrain, payload, and battery age. The table provides a rough estimate of charge time based on common distances travelled in regular operation.

**NOTICE:** The battery may take longer to charge when fully depleted, when very new, and after 3–5 years of regular use. If your battery doesn't seem to be charging normally, is taking longer to charge than expected, or you're experiencing substantial reduction in range, discontinue use and contact SLIDER Product Support.

## Long-term battery storage

If storing your SLIDER for longer than two weeks at a time, follow the recommendations below to maximize the performance and longevity of your battery.

For peak battery performance over time, store the battery at approximately 40-75% charged (about 4 to 7 charge level lights illuminated). Check the battery's charge level monthly. If necessary, use the charger from SLIDER to charge the battery to about 40-75% charged.

Storing your battery for long periods at full charge can cause range decline over time.

Do not store your battery at very little or no charge, which can cause permanent range decline or a non-functional battery.

You must read and understand all safety-related precautions in this section before handling, using, or storing the battery that came with your SLIDER.





**DANGER:** Never open the battery housing, which will void the warranty and can result in battery damage. It can also expose you to caustic substances and electrical shock or it could create a fire hazard, which can lead to serious injury or death.



 **WARNING:** Charging your battery with a charger other than one supplied by SLIDER and designed for your specific bike serial number can cause damage to your bike's electrical system or create a fire hazard. Only use a battery charger designed for your bike and supplied by SLIDER.

 **WARNING:** Letting the charger's plug contact metal objects could cause a power discharge (a spark), which could injure you or create a fire hazard.

 **WARNING:** Letting a battery charge unattended increases the risk that a charging problem will go undetected and lead to component damage or a fire hazard. Always charge your battery where you can monitor it.

 **WARNING:** Using a damaged battery or charger can create additional bike damage or a fire hazard. Stop using your battery and charger and contact SLIDER immediately if any of the following occur: (1) Your charger's flexible power cord or output cable or any of the electrical cables on your bike is frayed, has broken insulation, or any other signs of damage, (2) Your battery or charger is physically damaged, non-functional, or performing abnormally, (3) Your battery or charger experienced a significant impact from a fall, crash, or shipping damage, with or without obvious signs of damage, or (4) Your charger becomes too hot to touch (it's designed to get warm with normal use), makes an unusual smell, or shows other signs of overheating. Store any damaged battery or charger in a safe location and, as soon as possible, recycle or otherwise dispose of it according to local rules. Contact SLIDER Product Support if you have any questions or to purchase a compatible replacement battery or charger.

 **WARNING:** Using your battery at temperatures higher than 45°C (113°F) may cause permanent damage to the battery in the form of decreased range per charge for the remainder of the battery's life. At temperatures higher than 60°C (140°F), your battery can experience critical failure up to and including an electrical fire. Always store your battery at temperatures lower than 60°C (140°F). If you ride in extreme temperatures (above 45°C (113°F)), use low levels of power assistance to keep the battery as cool as possible.



**WARNING:** Never immerse or submerge the battery in water or liquid, including water in the battery mount, which can cause damage, serious injury, or death.



**WARNING:** Using aftermarket battery accessories or products that have not been tested by SLIDER for safety and compatibility may void your warranty, create an unsafe riding condition, result in bike/property damage, or cause serious injury or death. If you use products not tested and recommended by SLIDER, you do so at your own risk.



**CAUTION:** An unlocked or improperly attached battery can fall off a moving bike, causing damage or injury. Always check that the battery is properly attached and locked to the frame before moving or riding your bike.

**NOTICE:** Failure to follow the battery-charging best practices outlined in this chapter could result in unnecessary wear to the charging components, battery, and/or charger, and could lead to an underperforming or non-functional battery. Batteries damaged due to improper care will not be replaced under warranty.

**NOTICE:** When the battery is off its mount, protect the battery terminal contacts from damage and be sure not to touch them. If terminals are damaged, please discontinue use and contact SLIDER Product Support immediately.

**NOTICE:** Charging your battery in excessively hot conditions or interfering with its ability to aircool can damage your battery or charger. Always charge your battery at temperatures between 0°C to 45°C (32°F to 113°F), but preferably at room temperature: 10°C to 25°C (50°F to 77°F). Charging your battery at low temperatures may slow charging or prevent a full charge. Keep the battery and charger uncovered, make sure the charger is on a hard, flat, stable surface, and use the charger right-side-up (with charging lights facing upwards).

**NOTICE:** The charger is designed to stop charging automatically when the battery is full. Nevertheless, leaving your battery charging longer than necessary can cause needless wear. We recommend you remove the charger from the battery within one hour of the green light indicating a complete charge. Store the charger carefully, making sure its plug does not come in contact with liquids, dirt, debris, or metal objects, which can damage the plug and interfere with future operation.

**NOTICE:** Incorrect storage of your battery can result in a damaged or non-functional battery. Follow the above recommendations to reduce such risk.

**NOTICE:** Always follow any safety information attached to the battery or charger. A sample label for the battery that shipped with your bike is shown at right, some details and manufacturing location may differ.

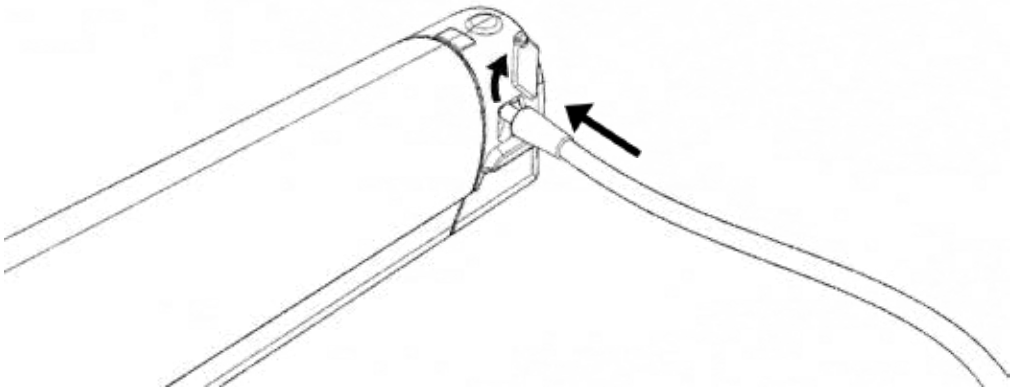

If you read all done, you can start to charge your SLIDER battery

Step 7 Fully Charged

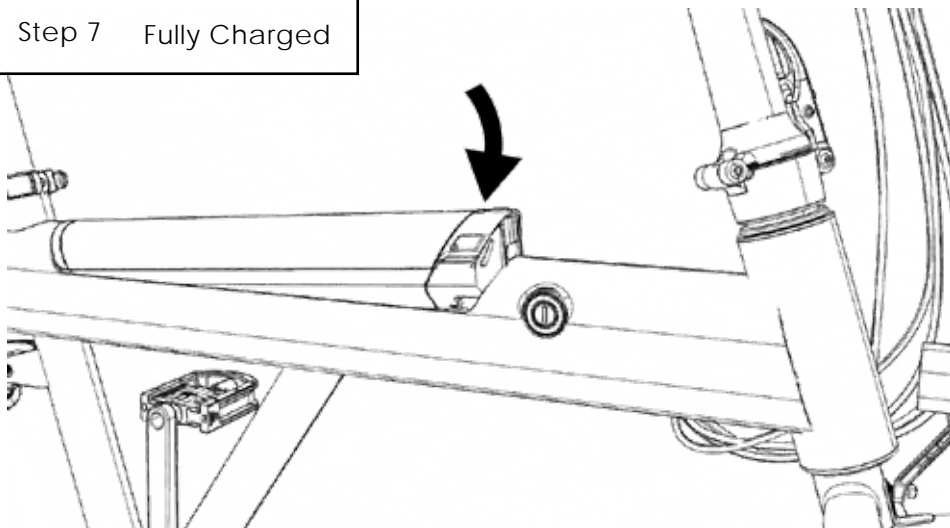

## INSTALLING THE BATTERY

To install the battery, you do not need the key. Check to ensure the battery mount is clean and dry, and then follow these steps.

1. Gently insert the battery into the frame.
2. Align the battery with the terminal contacts.
3. Push down on the battery until you hear a click. Do not force the battery into the battery mount. Ensure the battery is locked in place by gently pulling upwards on it.

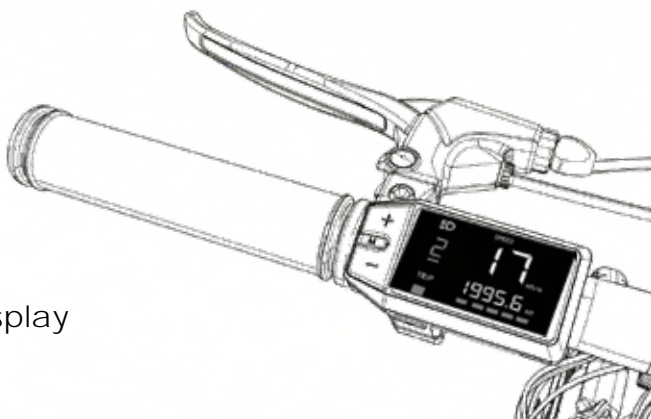

Turn on the display

Step 8 Test Function

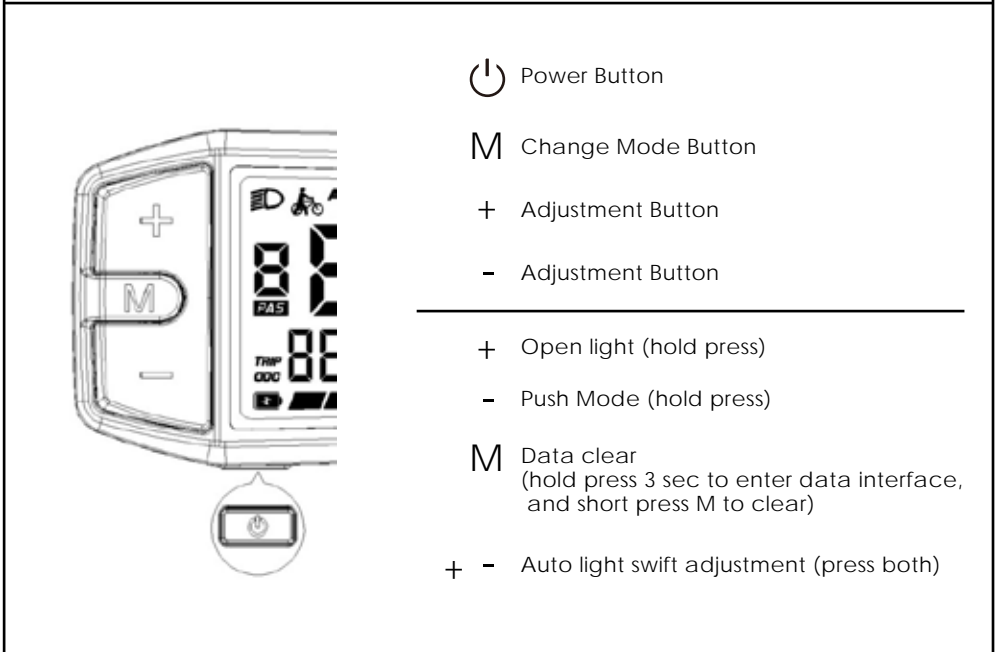
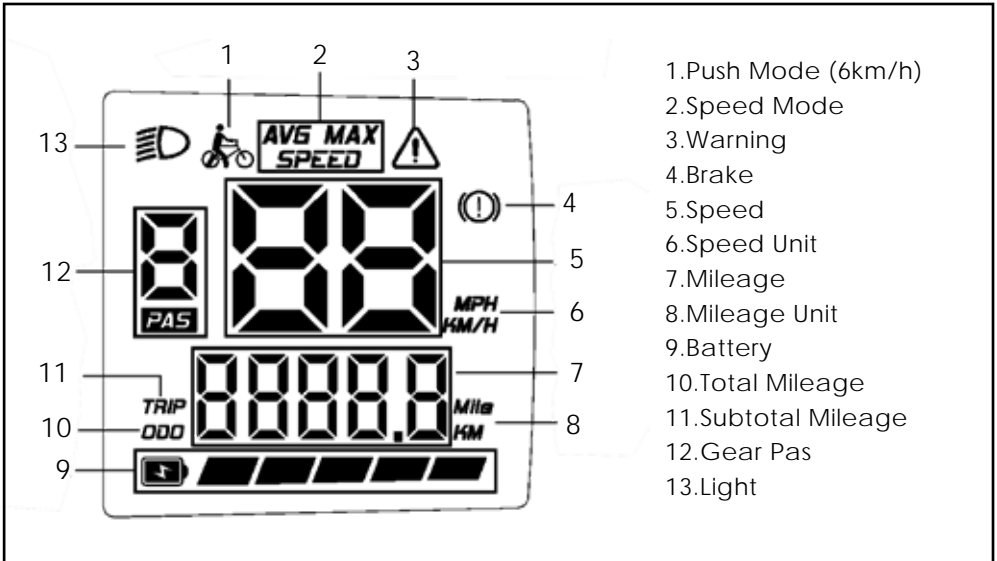

**!** DANGER: Improper use and unauthorized tampering with the EMS system is prohibited

## List of fault codes

Fault code (decimal)	Fault state	Remark
00	Normal status	-
01	Reserve	-
02	Brake	-
03	Power assist sensor failure (riding mark)	Not shown here
04	6 km/h cruise	Not shown here
05	Implement cruise	Not shown here
06	Battery undervoltage	-
07	Motor failure	-
08	Accelerator failure	-
09	Controller failure	-
10	Communication receiver failure	-
11	Communication transceiver failure	-
12	BMS communication failure	-
13	Headlight failure	-
14	Hall Motor failure	-

## Step 9 Test Function

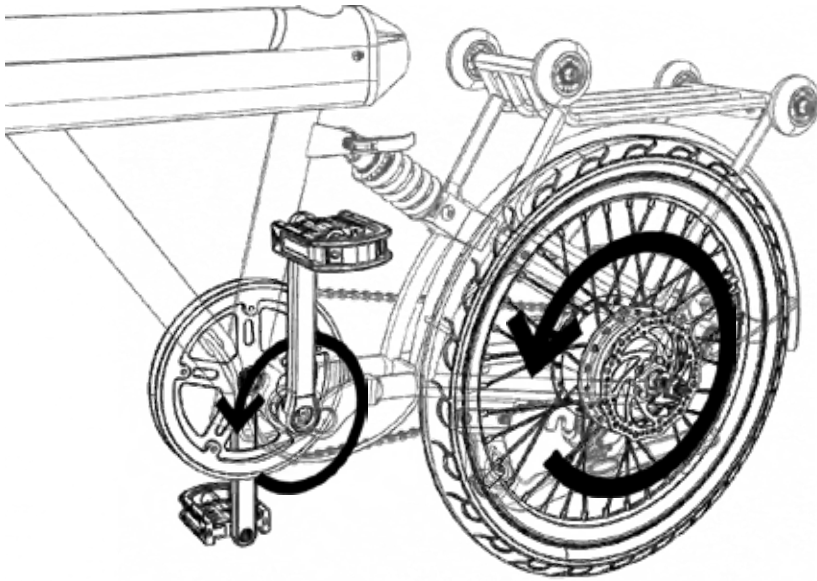

Turn the pedal to check if electric assist is available, which can be controlled through the meter.



## How the electrical system works

Your SLIDER is equipped with a pedal assist system (PAS) that provides power assistance from the motor to help propel the bike forwards.

### HOW PEDAL ASSIST WORKS

The rider can engage the pedal assist system (PAS) while pedalling, and it will call up assistance from the motor to help propel the bike forwards. Pedal assist uses a torque sensor built into the drivetrain of the bike. The torque sensor detects how hard the rider pedals and signals the electric motor to provide a corresponding level of pedal assist (so the harder you pedal, the more pedal assistance you get).

## Adjusting handle stem height

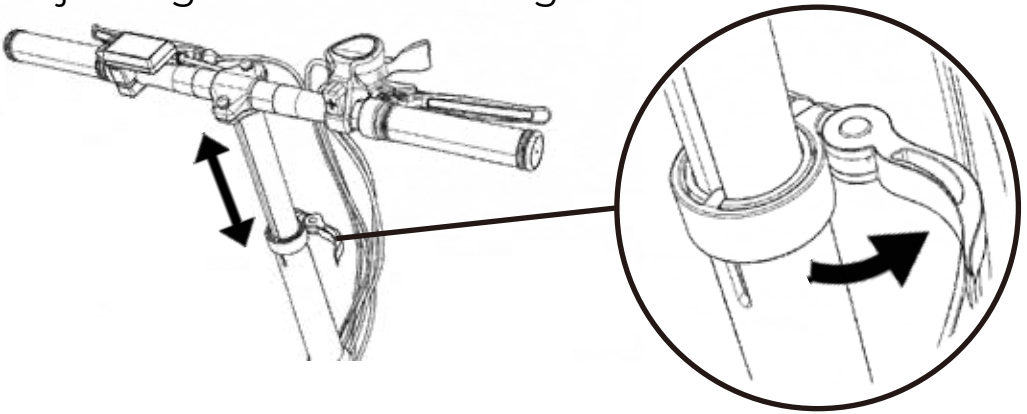

First unlock the quick release structure of the handle stem, and adjust the height according the height scale above. There are 12 stages of height adjustment, please do not too low or too high. Too low will cause riding discomfort, too high may cause the quick release structure to fail to lock tight the handle stem.

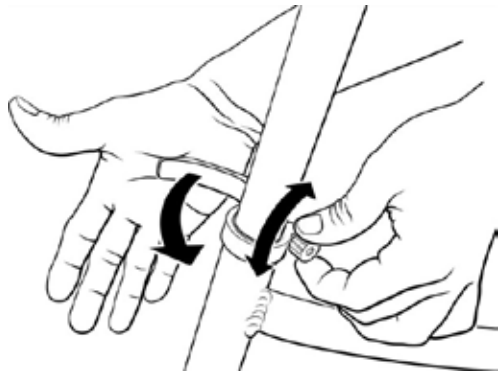
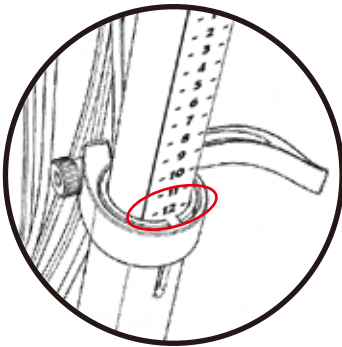

Align the quick release clamp opening with the notch in the stem tube, and close the quick-release lever fully. Closing the lever should require enough pressure that it leaves an imprint in your hand. When closed, the seat should not move up, down, left, or right. If needed, adjust the lever tension by turning the adjustment nut opposite the quick-release lever.

**!** **DANGER:** Overextending the seatpost can cause it to break or fall off your bike, which will put you at very high risk of serious injury or death. Avoid this danger by inserting your seatpost into the seat tube far enough that the minimum insertion point is no longer visible.



## Adjustment of brake system

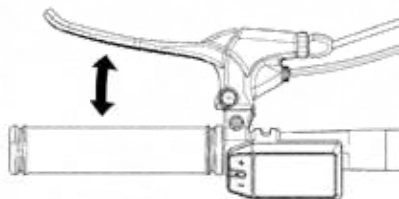
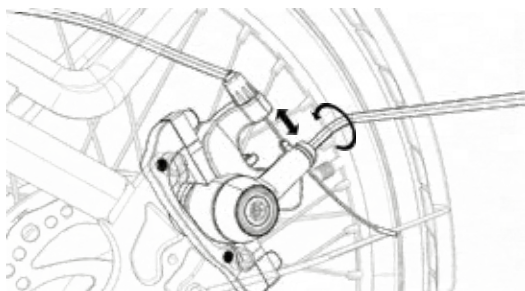

Test the brakes for proper operation

If the brake becomes loose, firstly position the screw on the brake caliper that matches the position shown in the picture. After loosening the screw, the rotating rod on the caliper will automatically rebound. After tightening the rotating rod upward or forward, then Tighten the screw, try to press the brake lever to confirm whether the braking effect is improved, and confirm that there is no friction between the rotor and the caliper when the wheel is turning.

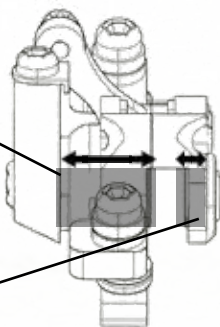
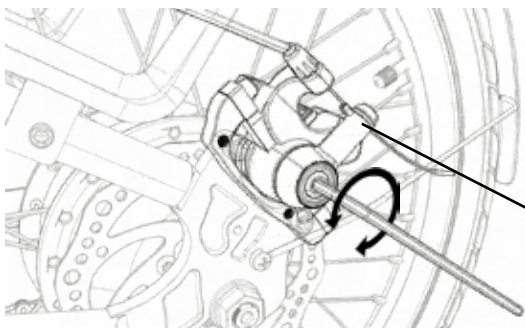

Adjust the band blocks

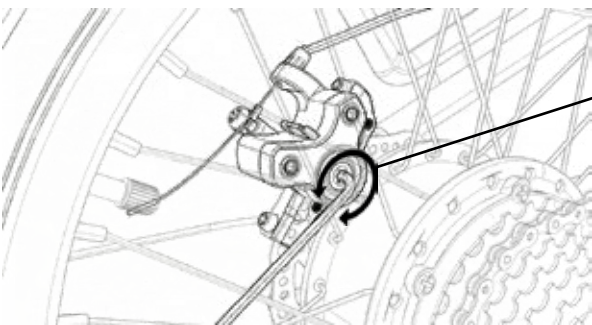

If there is a deviation between the position of the brake pad and the position of the rotor, it can be adjusted according to the adjustment method in the picture to achieve the best braking effect.

# Adjustment of Derailleur system

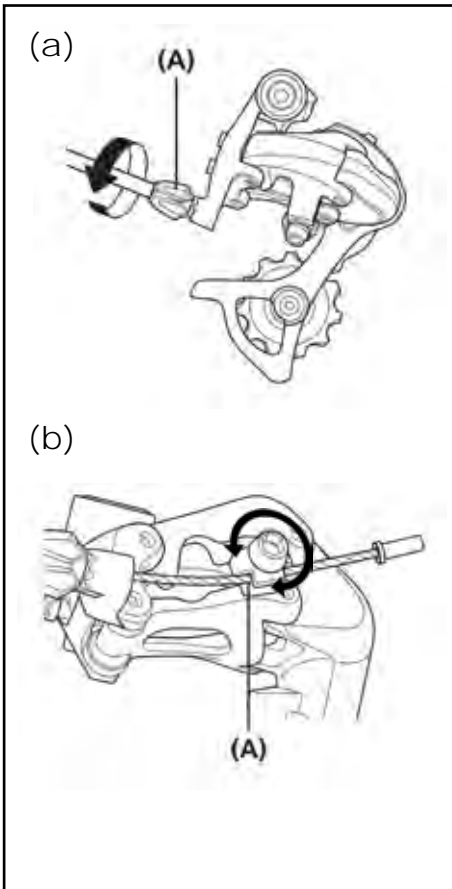

Fully details please check [www.shimano.com](http://www.shimano.com)

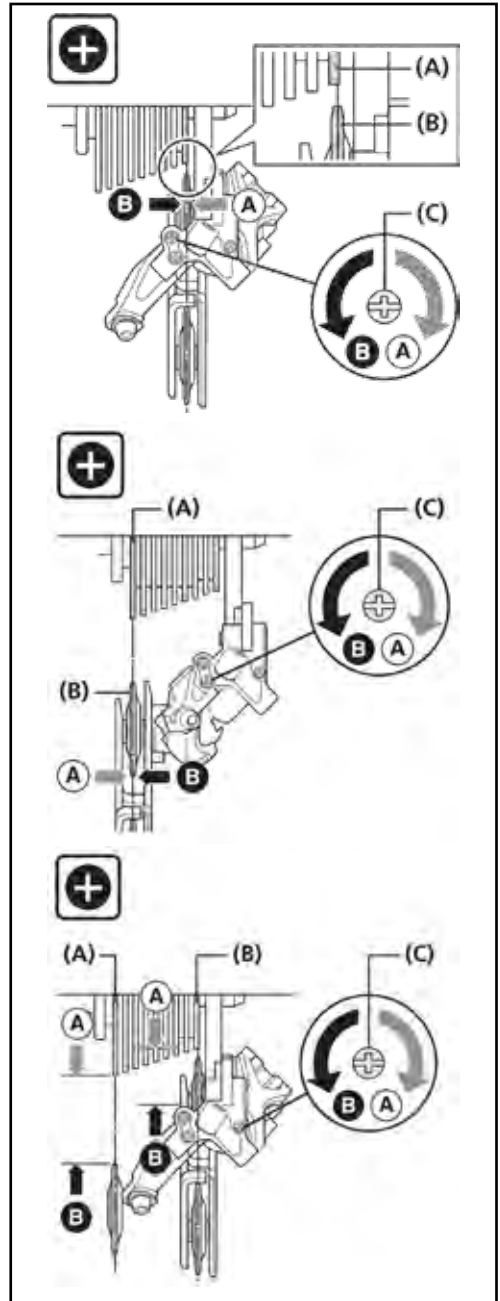

# Weight limits

The total maximum weight limit (payload capacity) of your ebike, listed below, includes the weight of the rider as well as clothing, riding gear, cargo, accessories, passengers.

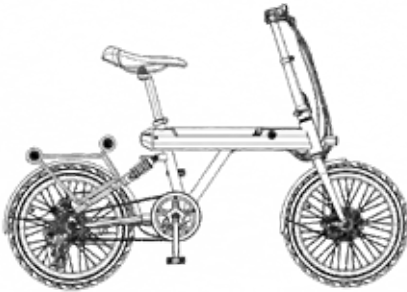

20kg



<100kg

Bike Weight : 20kg

Maximum payload of the Metro E3 (Safety Suggestion) : 100kg

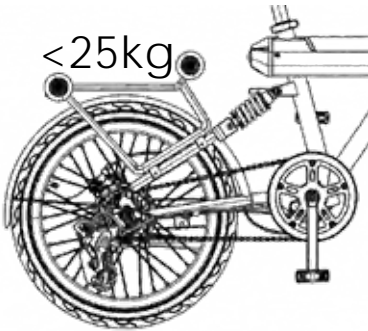

Rear rack maximum payload: 25 kg

The maximum payload capacity and other important safety information for specific SLIDER accessories will come with those products and/or be available online at [www.slider.eu](http://www.slider.eu).



**WARNING:** Never exceed the payload limit of any accessory or component of your bike even if you attach to it an accessory that carries a higher weight limit. Overloading any component can cause component failure, loss of control, serious injury, or death.

# Rear rack fixing structure and child seat restrictions

The rear rack and the frame are fixed with a four-point support structure. If the rear rack specifications of other manufacturers meet the fixed structure of the frame, it can be installed and used, but SLIDER not responsible for the maintenance and other responsibilities after modification.

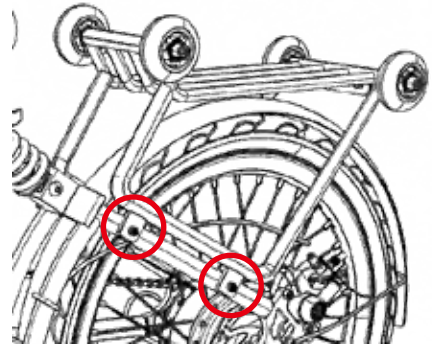

The rear rack width of SLIDER Metro E3 is 120mm. If you want to install a child seat, you must purchase a child seat that meets the installation width of 120mm.

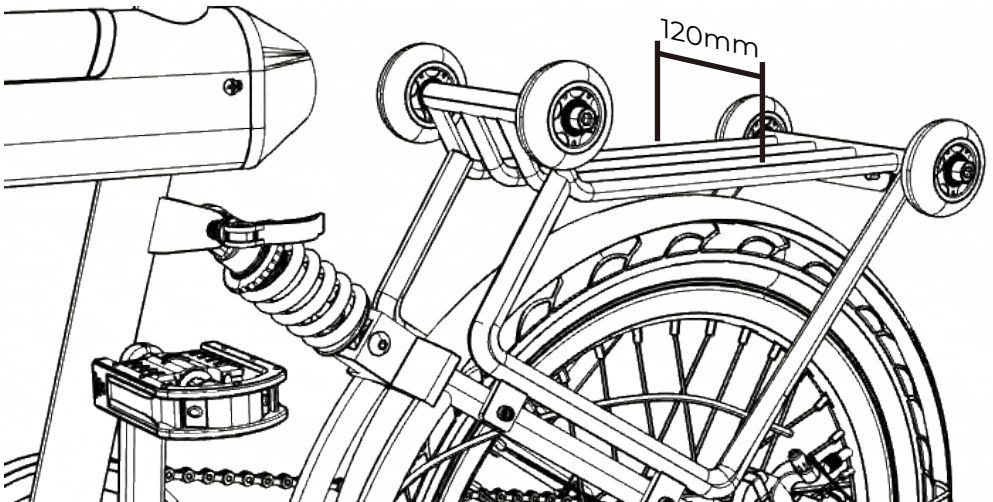

# Carrying loads (cargo or passengers) safely

Follow these recommendations to maximize safety when using your SLIDER to carry cargo or passengers.

- Carrying extra weight significantly affects braking, acceleration, turning, balancing, etc. These effects can be increased by challenging riding conditions, such as when roads are wet or slick. Hills that are normally easy to climb or descend without cargo can become challenging or even dangerous once extra weight is loaded onto the bike. Extra weight will increase the time it takes to slow the bike when braking.
- Practise riding with light cargo in a flat, open area that's free of obstacles before attempting to ride with heavier loads, and/or in wet or hilly conditions.
- With extra weight on your bike, it's more important than ever to use both front and rear brakes, and always engage the rear brake first to prevent excessive strain on the front wheel and fork and to prevent loss of control. Ensure both front and rear brakes are properly adjusted, maintained, and applied.
- Load cargo as low as possible to keep the bike's centre of gravity low and improve stability.
- Hold onto the bike when loading and carrying cargo and/or passengers. The kickstand is not designed to be used for loading cargo or passengers. Do not assume the bike is stable and balanced when using the kickstand.
- Ensure cargo loads are properly secured and periodically check that nothing loosens, risks interfering with any moving parts, or risks touching or dragging on the ground.
- When carrying heavy loads or passengers, plan your routes to avoid challenging hills and other hazards.
- It is always the rider's responsibility to ensure cargo or a passenger loaded on the ebike will not interfere with the rider's ability to safely operate the ebike.



WARNING: Failure to ensure that cargo or passengers can't interfere with the rider's control of the bike can lead to serious injury or death. The rider is always responsible for securing loads, loose straps, and assessing passenger's ability to ride safely. Please see "Carrying passengers" on the facing page for more information.



WARNING: Carrying cargo or passengers significantly affects braking, acceleration, turning, and balancing, which can increase the risk of falls and other accidents, potentially leading to property damage, serious injury, or death. To minimize such risk, practise riding with light cargo in a flat, open area before attempting to carry heavier cargo or passengers, especially on roads or hills and in wet conditions.



WARNING: Loading cargo or passengers without holding onto the SLIDER can cause the bike to tip, leading to damage or serious injury. The kickstand is designed to hold up an unoccupied, unloaded bike on a hard, flat, stable surface, not to support the weight of the rider, passengers, or cargo. Always hold onto your SLIDER when loading or unloading cargo or passengers.





WARNING: Using the front brake by itself can cause excessive stress on components, damage to the bike and parts, loss of control, injury, or death. Always apply the rear brake before applying the front brake, using both brakes for all operations.

## Carrying passengers

Your SLIDER is designed to carry one small child in a child seat. The seat must be attached to the built in rear rack.

 **DANGER:** Using your SLIDER to transport a passenger who is not the appropriate size or age for your child seat, or who does not have the health, motor control, or impulse control to ride safely as a passenger, can lead to serious injury or death of the rider or passenger. Read and understand the specifications of any child seat you purchase and all safety-, cargo-, and passenger-related information in this manual. It is your responsibility to assess the ability of a potential passenger to ride safely. If you're not certain, consult a physician.

 **DANGER:** Leaving a child unattended on a bicycle creates a VERY HIGH RISK of the bike tipping over, causing serious injury or death. Always remove your child from the bike before you look away or walk away from the bike.

 **WARNING:** To reduce the risk of injury, always closely supervise children if and when you use your SLIDER near them.

 **WARNING:** Serious injury or death can occur if clothing or body parts contact either wheel or other moving parts while the bike is in motion.

## Carrying pets

SLIDER understands that you may want to bring your pet along on your bike adventures, and we think that's SLIDER. We urge you to take great care to protect your furry friend and yourself. To check out the pet accessories that we have tested for safety and compatibility with our ebikes, please visit [www.slider.eu](http://www.slider.eu). We cannot recommend any pet carrier or restraint system that we have not tested for compatibility and safety with your ebike from SLIDER.

 **WARNING:** Transporting a pet using any bike puts you and your pet at risk of injury or death, especially if the pet distracts you, affects your balance, interferes with moving bike parts, etc. It's impossible to anticipate every situation that can occur while riding with a pet. If you carry a pet on any bike, you assume any and all inherent risks.

# Maintenance

Follow these maintenance guidelines to ensure your SLIDER is safe and fun to ride!

## Check and service your bike regularly

On any bike, certain parts need to be replaced periodically due to wear, and sometimes parts become damaged for various reasons. Check your bike before each ride. Have your bike regularly serviced by a certified, reputable bike mechanic.

Components of any ebike are subject to higher wear compared to the components of bikes without power assistance. This is because ebikes can travel at higher average speeds than regular bicycles and generally weigh more. Higher wear is not a defect in the product and is not subject to warranty. Typical components affected are the tyres, brake pads and rotors, suspension forks, spokes, wheels, and the battery.

If you need to replace a part on your bike, visit [www.slider.eu](http://www.slider.eu). If you want something that isn't listed there, contact SLIDER Product Support. Be extremely careful about using parts or accessories that SLIDER has not tested for safety and compatibility with your specific bike model.



**WARNING:** Using aftermarket accessories or components (trailers, stands, vehicle racks, etc.) that have not been tested by SLIDER for safety and compatibility with your specific bike may void your warranty, create an unsafe riding condition, result in bike/property damage, or cause serious injury or death. If you use replacement parts or accessories not tested and recommended by SLIDER, you do so at your own risk.



# Safety checklists

## BEFORE YOUR FIRST RIDE

- Make sure handlebar cables were routed correctly when the handlebar was installed. Turn the handlebar fully to the left and right and make sure this doesn't pull any of the cables or wires taut.
- Make sure your pedals are secure using a pedal wrench. Torque to 35 Nm. Check that the cable connectors on the bike are all plugged in securely and that nothing loosened in shipping.
- Check the brake functions per the directions note that brakes can rub a little the first few times you ride. This is okay and normal; any squeak or noise should go away with use.
- Check everything on the "Before every ride" list below.

## BEFORE EVERY RIDE

Before every ride or every 40–72 km (25–45 miles), follow the safety checklist in the table below. If you find anything amiss with your bike, don't ride it until you're sure it's fixed. Consult a local, certified, and reputable bike mechanic or explore our Help Centre at [www.slider.eu](http://www.slider.eu) if you have any questions.

### Fasteners:

- Ensure all fasteners are correctly tightened according to the specifications .
- Check that all quick release levers, including the quick release on the front wheel and the seatpost, are tight and properly secured. Ensure the front wheel quick release lever is positioned so that the front fork lower doesn't prevent it from closing fully.
- Check that the fasteners on any accessories you've added are properly tightened according to the manufacturer's instructions.

# Safety Riding Instructions

Make sure you are wearing a HELMET and other safety gear (e.g. knee pads, elbow pads)



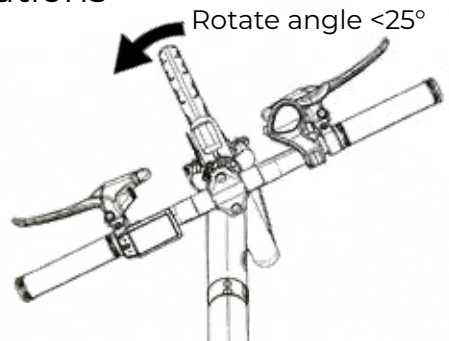
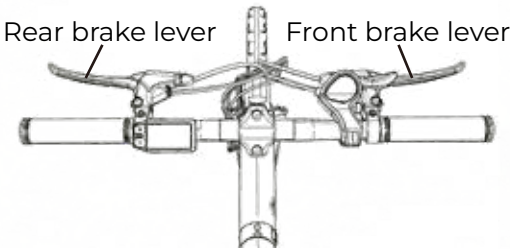

 **WARNING :** SLIDER Metro E3 belongs to urban bicycles. The frame design is specially developed for urban riding, which can ride for a long time and face daily bumpy terrain. However, please do not ride SLIDER in places with severe terrain, such as mountainous terrain and ladder. SLIDER will not be responsible for any danger or damage caused by this.

## Cycling Steering Safety Limitations

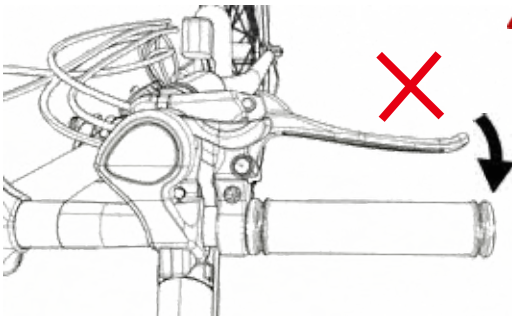

When steering while riding, the handlebar rotation angle should not exceed 25 degrees as much as possible to maintain stability during riding. If the steering angle is too large, it will cause unstable driving and cause danger.



 **DANGER:** The braking method should be to brake the rear wheels before braking the front wheels, and it is forbidden to activate the front wheel brakes at the same time when turning. This practice will lead to skidding and overturning, causing injuries to riders or accidents. SLIDER are not responsible for this .

## Brake system:

-Check brake pads and ensure the brake pad material isn't thinner than the backing plate it attaches to. Ensure brake pads are correctly positioned in relation to the brake rotors.

-Ensure brake housing shows no obvious wear.

-Ensure brake levers are properly positioned and tightly secured to the handlebar.

-Ensure the brake lever tension is appropriate.

## Wheels & tyres:

-Ensure tyres are holding air and inflated to within the PSI limits displayed on the tyre sidewalls.

-Ensure tyres have good tread, have no bulges or excessive wear, and are free from any other damage. Ensure rims run true and have no obvious wobbles, dents, or kinks. See "Tyre and wheel care" . Check each wheel spoke. If any are loose or broken, seek help from a certified, reputable mechanic.

-Check the axle nuts on the rear wheel to ensure they are correctly tightened.

-Check the security of the front-wheel quick release and the rear wheel mounting hardware. The wheel security and hardware torque should also be checked on a regular basis . Either wheel can become loose or unsecured with normal use.



**WARNING:** An improperly secured front or rear wheel can cause loss of control, accidents, serious injury, or death. Check that both wheels are properly secured during assembly and before each ride.

## Steering:

- Ensure the handlebar and stem are correctly aligned, adjusted, and tightened for proper steering.
- Perform a handlebar twist test to ensure the stem clamp bolts are secure.
- Ensure the handlebar is set correctly in relation to the fork and the direction of travel.
- Ensure the handlebar grips are secure and undamaged.

## Bearings:

- Check that headset, wheel, pedal, and bottom-bracket bearings are lubricated, run freely, and display no excess movement, grinding, or rattling.

## Drivetrain: cranks, pedals, chain, derailleur, shifter:

- Ensure pedals are securely tightened to the cranks.
- Ensure the cranks are not bent and are securely tightened to the bottom bracket.
- Ensure the chain is clean, lubricated, and runs smoothly. Take extra care with chain maintenance if the bike is used in wet, salty, dusty, or otherwise damaging conditions.
- Check that the derailleur is adjusted and functioning properly.
- Ensure the shifter is attached to the handlebar securely and is shifting properly.

## Frame, fork, and seat :

Check that the frame and fork are not bent or broken.

Check that the seat is adjusted properly, the seatpost quick-release lever is securely tightened, and the seat does not move when the lever is closed.

Ensure that the seatpost minimum insertion marking is fully inserted into the frame.

## Motor drive assembly:

Ensure the hub motor is spinning smoothly and is in good working order.

Ensure the power cable running to the hub motor is secured and undamaged.

Check the axle nuts to ensure they are correctly tightened.

Ensure the torque washers, torque arm, and torque arm bolt are in place and secured.

Ensure the pedal assistance is operating normally.

## Battery:

-Ensure the battery is charged.

-Ensure there is no damage to the battery.

-Ensure the battery is locked to the frame and is secured. Remove the key before riding.

-Ensure the battery gauge on the SLIDER UI Display and the charge status indicator on the battery read similarly.

## Cables:

Look over electrical cable connectors to make sure they are fully seated and free from debris or moisture. Check cables and cable housing for obvious signs of damage.

Ensure cables are secured away from moving parts.

Ensure headlight, taillight, and brake light are functioning, adjusted properly, and unobstructed.

## Accessories & safety gear:

Ensure all reflectors are properly fitted and not obscured.

Ensure all accessories and components installed on the bike are properly secured and functioning according to their manufacturer's specifications.

Check all safety gear, clothing, cargo, and accessories for loose or potentially loose straps/elements and secure them. Ensure rider and any passengers are wearing a helmet and other required riding safety gear, and inspect these items for signs of damage.

If your bike has fender/mudguards: Ensure they are centred over the wheels, adjusted properly, properly secured, and have no cracks or holes.



**WARNING:** Riding your bike when any component's useful life is surpassed can cause that component to fail, resulting in loss of control, serious injury, or death. Pay attention to signs of wear such as cracks, scratches, component colour change, and operational changes that could indicate a component needs replacing. Before each ride, check your bike using the "Safety checklists". Perform regular maintenance according to "Recommended service intervals" below. If you're not sure you have the experience, skills, and tools to perform safety checks and regular maintenance, consult a local certified, reputable bike mechanic for help.

## AFTER EVERY RIDE

Store your bike and battery in a dry location and take other sensible precautions as described in “Parking, storage, and transport”

Guard against damage from the elements by following the recommendations in “Guard against rust, corrosion, and water damage”

Charge your battery in a temperature-controlled location and follow the recommendations in “Battery information”

### Recommended service intervals

Regular maintenance of any bike is key to ensuring the best possible performance and reducing wear and tear on systems. Ideal service intervals vary depending on use conditions. We generally recommend inspections, service, and necessary replacements be performed at the time and distance intervals described below, but you should have your bike serviced more frequently if you ride aggressively, with heavy payloads, or in harsh conditions. Have your bike inspected immediately if you notice problems or your bike has been involved in a fall or other accident.



**WARNING:** Have your bike inspected by a certified, reputable bike mechanic after any fall, crash, or accident, as these can cause damage (visible or internal/not readily apparent), make your bike unsafe, and lead to serious injury or death. Be particularly cautious about using a battery that has experienced a significant impact from a fall or crash; a damaged battery may not show external signs of damage. Using a damaged battery or charger can create additional bike damage or a fire hazard. For more information, see “Battery information”



**WARNING:** Attention to the rider concerning possible national legal requirements when EPAC is to be ridden on public roads (e.g. lighting and reflectors)

## AFTER BREAK-IN PERIOD OF 80–160 KM (50–100 MILES)

### Inspect:

- Check all cables and the chain for stretch.
- Check spoke tension and the trueness of the wheels.
- Check all bolted connections for loosening and ensure they are tightened to recommended torque values.

### Service:

- Have a certified, reputable bike mechanic perform a thorough tune-up.



**WARNING:** Certain components can stretch or loosen during any bike's break-in period, which can lead to component failure and potential injury or death. Be sure to have a certified, reputable bike mechanic perform a thorough tune-up after this break-in period or sooner if you notice any problems or if you ride aggressively, with heavy payloads, or in harsh conditions.

## WEEKLY, 160–320 KM (100–200 MILES)

### Inspect:

- Check hardware for proper torque.
- Check drivetrain for proper alignment and function (including chain, freewheel, chainring, and derailleur).
- Check wheel trueness and spoke tension, and check for quiet wheel operation (without spoke noise). Check frame for any damage.



## Service:

- Clean frame by wiping frame down with damp cloth.
- Clean and grease the chain.

## Replace:

- Replace any components confirmed to be broken or damaged beyond repair by SLIDER Product Support or a certified, reputable bike mechanic.

## MONTHLY, 400–1200 KM (250–750 MILES)

## Inspect:

- Check brake pad wear, alignment, and the brake lever tension.
- Check for proper shifting and proper derailleur cable tension.
- Check chain stretch.
- Check shifter cables for corrosion and fraying.
- Check wheel trueness and spoke tension, and check for quiet wheel operation (without spoke noise).

## Service:

- Clean and lubricate drivetrain.
- Check crankset and pedal torque.
- Clean shifter cables.
- Tension spokes and true wheels if any loose spokes are found.

## Replace:

- Replace shifter cables if necessary.
- Replace brake pads if necessary (typically when the pad material is thinner than the backing plate).

EVERY 6 MONTHS, 1200–2000 KM (750–1250 MILES)

## Inspect:

- Inspect drivetrain (chain, chainring, freewheel, and derailleur).
- Inspect all cables and housings.

## Service:

- Standard tune-up by certified, reputable bike mechanic.
- Grease bottom bracket.

## Replace:

- Replace brake pads.
- Replace tyres if necessary.
- Replace cables and housings if necessary.

---

## Checking brakes & motor cutoff switches

All vehicles, including your SLIDER, need reliable brakes. Test your brake levers, brakes, and motor cutoff switches for proper functioning before every ride. If anything seems wrong, take your bike to a local, certified, and reputable bike mechanic, refer to our Help Centre ([www.slider.eu](http://www.slider.eu)), or contact SLIDER Product Support.



**WARNING:** Touching the brake rotor, which has sharp edges and can get very hot while you're riding, can cause serious injury, slicing damage, or burns. The brake rotor heats up from normal friction when the brake pads press against the brake rotor to slow or stop the bike. Touching the brake rotor with bare skin can also transfer natural oils to the rotor, which can decrease braking performance. Do not touch the brake rotor, especially when it's in motion or after you've been riding your bike. Touch the brake rotor only for necessary maintenance when it is cool, not moving, and while you are wearing gloves or using other appropriate protective equipment.

#### 1. Test the brake levers.

- a. Fully squeeze each lever, and ensure neither the front nor rear brake lever touches the handlebar grips.
- b. Ensure both brake levers are properly lubricated. If they are, they'll be reasonably easy to squeeze without feeling as though there's grit in the mechanism. When you release them, they will immediately go back to their original position.
- c. Make sure each lever is properly oriented and firmly secured to the handlebar.

#### 2. Test each brake.

- a. Squeeze the left brake lever to lock the front brake, and then try to push the bike forwards using the handlebar. The front wheel should not spin.
- b. Squeeze the right brake lever to lock the rear brake. Again, push against the handlebar to try moving the bike forwards. The rear wheel should not spin.

### Tyre and wheel care

The tyres and inner tubes that came with your ebike are designed for durability and safety for regular cycling activities. Wheels and tyres need to be checked before each use to make sure they're in good condition. Always replace tyres and inner tubes that have punctures, cuts, bulges, damage, or excessive wear before you ride.

## TYRE INFLATION

Inflate tubes and tyres to within the PSI range stamped onto the tyre sidewall. For additional information about tyre pressure, please consult our Help Centre at [www.slider.eu](http://www.slider.eu).



**WARNING:** Underinflating your tyres can result in loss of control. Overinflating can make tyres burst. Either scenario can lead to serious injury or death. Always maintain the correct air pressure of your tyres, which is listed on the tyre's sidewall, and use a regulated air source with pressure gauge so that you can measure pressure accurately.

## WHEEL "TRUENESS"

Your wheels should always spin straight ("true") and must be repaired or replaced if they wobble side to side or up and down when spinning. To test them, do this:

1. Spin the wheel.
2. Brace a dull pencil against the frame or fork, with the tip just touching the rim.

If the gap between the spinning rim and pencil changes more than 5 mm, your wheels may need truing. If your wheels become untrue or if spokes loosen, which can happen with normal use, we recommend that you have a certified, reputable bike mechanic perform wheel tuning and truing operations. Do not attempt to true wheels or tighten spokes unless you have the highly specialized skills and tools to do so.

## TYRE REPLACEMENT

Even tyres equipped with built-in flat-preventative tyre liners, like those that come with your SLIDER, can and do get flats from punctures, pinches, impacts, and other causes. If you get a flat tyre or see evidence of tyre wear, you must replace your tyre and/or tubes before operating the bike again. Otherwise, you risk bike/property damage, serious injury, or death.



**CAUTION:** Removing a tube from your wheel rim before the air has been released from it can cause the tube to burst, potentially causing serious injury. Always release air pressure before removing your tube.



**WARNING:** Aftermarket tyres or inner tubes not provided by SLIDER may not be compatible with your wheels or the performance requirements of your ebike. Such tyres can fail or create unsafe riding conditions, causing serious injury or death. Always use replacement tyres and tubes that are sized to be compatible with your bike frame. For safety, and if required by law, ensure replacement tyres have sufficient reflective sidewall striping.

For more information on tyre or tube replacement, visit [www.slider.eu](http://www.slider.eu) or contact SLIDER Product Support.

## Handlebar twist test



**WARNING:** An improperly secured wheel and/or handlebar stem can cause loss of control, accidents, serious injury, or death. Check that the front wheel and handlebar stem are properly secured during assembly and before each ride.

- 1.Brace the front wheel. Stand at the front of the bike, facing the handlebar, and brace the front wheel between your feet and lower legs.
- 2.Try to twist the handlebar. Hold both handlebar grips and push forwards with one hand while pulling back with the other. Push and pull at the same time with about 20 lb of force with each hand.
- 3.Ensure the handlebar and wheel stay properly aligned. The handlebar and handlebar stem should be tightly secured, and the handlebar should be perpendicular to the front wheel.
- 4.Repeat the twist test pulling/pushing with the opposite hands, using about 20 lb of force pushing with one hand and 20 lb of force pulling with the other hand.
- 5.If needed, align the handlebar and stem and torque the stem clamp bolts evenly. Be sure to torque the stem clamp bolts evenly to the specification. After torqueing the stem clamp bolts to the proper specification, perform the twist test again. If the handlebar still moves, contact SLIDER Product Support.



**WARNING:** If you are not sure you have the experience, skills, and tools to correctly perform all steps to secure and verify the security of the handlebar, front wheel, and handlebar stem you **MUST** consult a certified, reputable bike mechanic to check your work and/or secure those components to the bike properly.

## Guard against rust, corrosion, and water damage





**WARNING:** Damage to your ebike's electrical system caused in any manner, including water intrusion, can lead to battery failure, electrical system malfunction, or electrical fire and consequent property damage, injury, or death. Follow all recommendations to minimize chance of water damage. If you have any questions, contact SLIDER Product Support.

Like any vehicle used outdoors, your SLIDER needs care to ensure it isn't damaged by the elements. Follow these steps for a long, healthy life for your ebike:

1. Store under shelter and in an upright position; avoid leaving the bike in the rain or exposed to corrosive substances such as water, salt, or deicing substances. If exposed to rain, dry your bike afterwards, and apply an anti rust treatment to the chain and other unpainted steel surfaces.
2. To clean your ebike, turn the bike and battery off and wipe the frame with a clean, damp cloth. If needed, apply a mild, non- corrosive detergent mixture to the damp cloth and wipe the frame. Dry by wiping with a clean, dry cloth. Never use high- pressure water on your bike. Wipe down your bike frequently and wipe or spray all unpainted mechanical parts with anti- rust treatment.
3. If painted metal parts become scratched or chipped, use touch up paint or nail polish to prevent rust.
4. Never immerse or submerge the bike or any components in water or liquid, which can damage the electrical system.
5. Avoid riding on the beach, in coastal areas with high-salinity fog, or on surfaces treated with salt or deicing compounds. Doing so exposes your bike to salt or other substances that are very corrosive. Corrosion of electrical components can lead to permanent damage that can cause battery failure, electrical system failure, or electrical fire. Damage from corrosion is not covered under warranty.

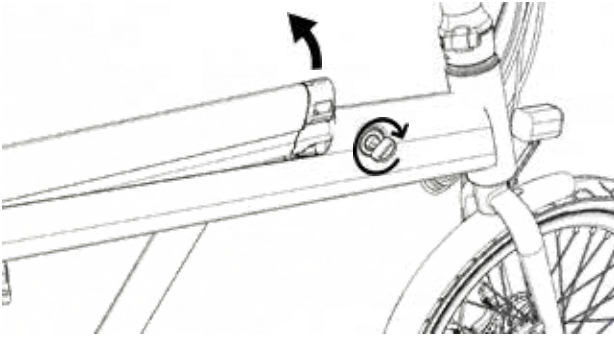
## Bike cleaning Maintenance



 Before cleaning the car, please make sure to remove the battery first, so as not to lose the function of the parts printed on the battery when it comes into contact with water.

## Cleaning precautions

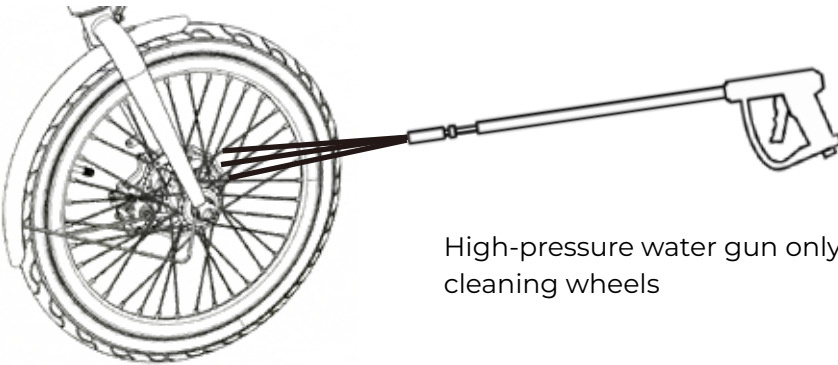

High-pressure water gun only for cleaning wheels

High-pressure water guns can be used for cleaning, but only for the front and rear wheels. Avoid using high-pressure water guns when cleaning the car body, so as not to cause water to easily enter the car and cause problems with electronic components.

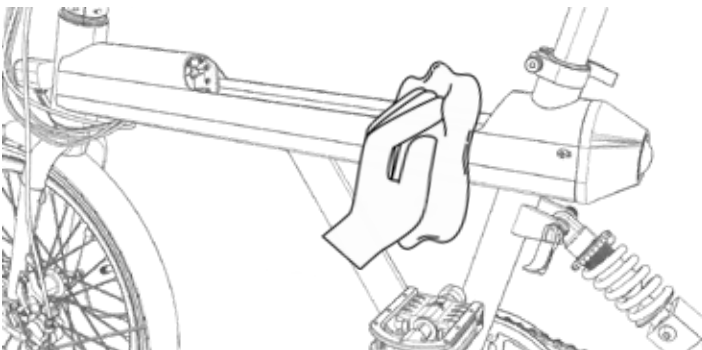

Recommended to wipe the car body with a damp cloth. Using a high-pressure water gun may damage the electronic parts in the frame and damage the paint on the car body.

## Chain Cleaning Maintenance

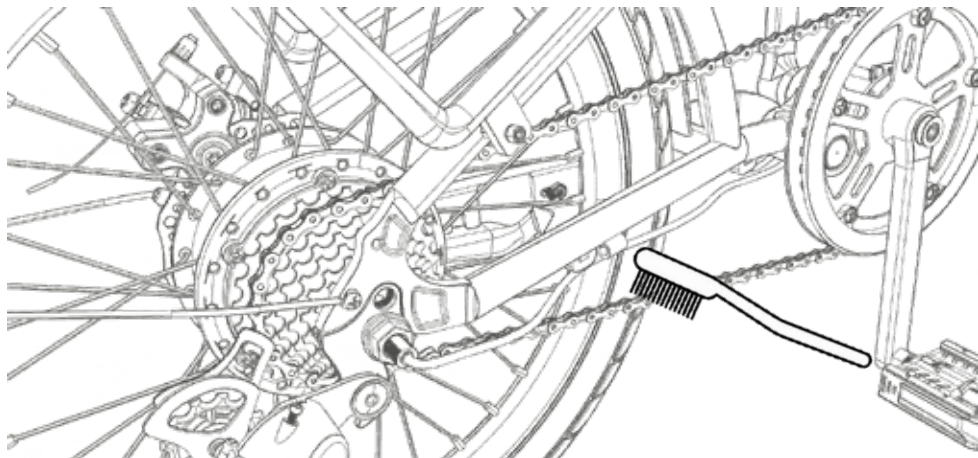

When cleaning the chain, use a brush to clean the dust and silt on the chain, prolong the service life of the chain and keep the freewheel clean, so as to prevent the freewheel from accumulating too much dirt and affecting the use of the transmission.

After cleaning, spray butter can be used on the freewheel to enhance the smoothness of riding and slow down the rust of the freewheel.

(Lubrication maintenance can be carried out once a month)

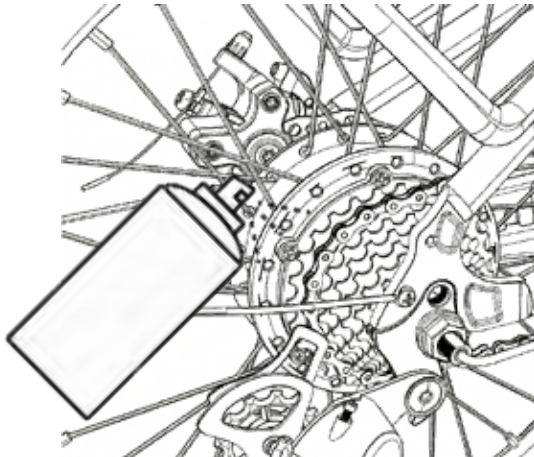

 If the electronic parts touch the water during the cleaning process, it will cause a short circuit of the wires, which will not only cause damage to the parts, but also cause riding hazards.



# Troubleshooting

Problems	Solution
A. You turn the power on, the indicator lights are all on, but with throttle or	<ol style="list-style-type: none"> <li>1. Your controller needs to be replaced, or</li> <li>2. Your motor needs to be replaced.</li> </ol>
B. You turn the power on, the indicator lights are all on, bike works with throttle, but not with	<ol style="list-style-type: none"> <li>1. Your controller needs to be replaced, or</li> <li>2. Your pedal assist module needs to be replaced, or</li> <li>3. Your motor needs to be replaced.</li> </ol>
C. You turn the power on, the indicator lights are all on, bike works with pedal assist, but not	<ol style="list-style-type: none"> <li>1. Your controller needs to be replaced, or</li> <li>2. Your throttle needs to be replaced, or</li> <li>3. Your motor needs to be replaced.</li> </ol>
D. You turn the power on, then twist the throttle, but the ebike doesn't work.	<ol style="list-style-type: none"> <li>1. Check your battery to see if it needs to be charged, or</li> <li>2. Your fuse needs to be replaced, or</li> <li>3. Your controller needs to be replaced, or</li> <li>4. Your motor needs to be replaced.</li> </ol>
E. The switch is turned on, and the ebike takes off without using the throttle.	<ol style="list-style-type: none"> <li>1. Check whether the throttle is stuck in the on position.</li> <li>2. Lubricate or replace the throttle if it is faulty.</li> </ol>
F. After stopping, the ebike doesn't start when the throttle is twisted.	<ol style="list-style-type: none"> <li>1. Check whether the brake handles are fully released.</li> <li>2. Check A., B., and C. above.</li> </ol>
G. The speed is unusually slow.	<ol style="list-style-type: none"> <li>1. Make sure throttle is operating correctly.</li> <li>2. Check to see if the battery is fully charged.</li> <li>3. Make sure speed limiter is not connected.</li> </ol>
H. You connect the power to the charger, but the indicator light	<ol style="list-style-type: none"> <li>1. Check whether there is electricity to the charger.</li> <li>2. If you have a voltage meter, you can check to see if the charger produces the correct current.</li> </ol>
I. You plug in the charger to the ebike and the outlet, and the	<ol style="list-style-type: none"> <li>1. Check to see if the batteries are fully charged.</li> <li>2. Check whether the charger is plugged in properly to both the battery and the outlet.</li> <li>3. Check the voltage of the charger and battery.</li> <li>4. If "zero" voltage on the charger, then it needs to be replaced.</li> <li>5. If "zero" voltage from the battery, then check the fuse.</li> </ol>

If all above mentioned situations are normal, then there is some other problem. Please call your local Liberty ebike dealer.

## Ride as safely as possible

SLIDER products of the A-weighted emission sound pressure level at the driver ears is less than 70 dB(A)

Ride SLIDER by taking the sensible measures outlined in this section to maximize your safety. Bicycling is an exciting, delightful, and practical way to get around, but like any sport, it involves risk of injury and death. By choosing to ride a bike, you assume responsibility for those risks.



**WARNING:** Incorrect assembly, maintenance, or use of your ebike can cause component or performance failure, loss of control, serious injury, or death. Even if you're an experienced bike rider, you must read and understand the entire manual and any documentation provided for subcomponents or accessories before riding. If you are not sure you have the experience, skills, and tools to correctly perform all assembly steps in the manual and the assembly video at [www.slider.eu](http://www.slider.eu), consult a local, certified, reputable bike mechanic.

## Be thoroughly educated about your bike before riding it

Practise riding your bike, braking, shifting gears, and using the pedal assist systems in a controlled location before venturing into traffic or other risky conditions.

The electrical system on your ebike offers various levels of power assistance and lighting for different operating conditions and user preferences. Be sure you understand these features before riding. If the pedal assistance or lighting is functioning abnormally, intermittently, or not at all, please discontinue using your ebike immediately and contact SLIDER Product Support for assistance.

Take extreme care getting to know and learning to control the pedal assist and brake systems. Your SLIDER is probably heavier than other bikes you've ridden, and it will handle quite differently from lighter bikes, especially when you're accelerating or decelerating. Learn to maintain a comfortable stopping distance from all other objects, riders, and vehicles at different speeds, conditions, and with varying payloads.

## Age and ability requirements

The SLIDER is designed for persons at least 16 years of age, and a parent or legal guardian should always decide whether a child should operate or ride on the SLIDER or any other vehicle.

**NOTICE:** Some localities may require ebike riders to be older than 16. It is your responsibility to know and obey local regulations regarding rider age and other qualifications.

Riders must also have the physical ability, reaction time, and mental capability to understand and obey all local laws governing ebike usage and to manage traffic, variable road conditions, and sudden situations. If you have an impairment or disability (e.g., visual impairment, hearing impairment, physical impairment, cognitive or language impairment, seizure disorder) or any other limitation that could affect your ability to safely operate a vehicle, consult your physician before riding any bike.



**DANGER:** Riding any bike under the influence of alcohol, drugs, or any substance or condition that could impair your motor function, judgment, reaction time, or ability to safely operate a vehicle puts you at **VERY HIGH RISK** of serious injury or death. Operate bikes and other vehicles only when you're sober and otherwise physically and mentally prepared to ride safely.

## Safety check before each ride

Before each ride, you must check your bike to ensure everything is working properly. Follow the instructions on the “Safety checklists” and ground your safety checks in a solid understanding of bike maintenance, a section that includes an important chart, “Recommended service intervals”, which you should follow as well.

If you are ever unsure how to check or maintain your bike or if you find any problems with it, take it to a certified, reputable bike mechanic or contact SLIDER Product Support.

## Ride appropriately for conditions

Always travel at speeds appropriate for local terrain and conditions as well as your experience level. When in doubt, slow down.



**WARNING:** Using the front brake by itself can cause excessive stress on components, damage to the bike and parts, loss of control, injury, or death. Always apply the rear brake before applying the front brake, using both brakes for all operations.

Always use a low pedal assist level until you are comfortable with your SLIDER and confident about controlling its power, weight, and responsiveness (e.g., during start-up, turns, and braking) at different speeds, in different conditions, and with whatever payloads you might carry.

Riding with your headlight on will make you more visible in any conditions. The headlight will turn on when the bike is powered on. We recommend you keep it on whenever you ride.

Concentrate on the path ahead. Avoid potholes, gravel, ice, wet or oily roads, wet leaves, kerbs, train tracks, speed bumps, drain gates, thorns, broken glass, and other obstacles, hazards, and puncture-flat risks.



**WARNING:** Crossing train tracks or similar grooved or raised surfaces at a diagonal can make the surface “grab” or deflect your wheel, causing your bike to suddenly get stuck or crash, leading to serious injury or death. Always cross such hazards at a perpendicular angle or, when in doubt, dismount and walk your bike across.

## PATH RIDING

Be a good citizen of shared-use paths and facilities. Keep your speed reasonable and below path speed limits, pass carefully and kindly. Use your voice and/or bell to signal your presence to others, especially when passing.

## ROAD RIDING

When riding on streets, obey the same road laws as all other road vehicles as well as local rules governing bike or ebike usage. Sharing the road with other vehicles presents many hazards. Always take these precautions:

- Expect the unexpected such as opening car doors or cars backing out of driveways.
- Be extra careful at intersections and when preparing to pass other vehicles or other cyclists.
- Ride predictably, in a straight line, and with the flow of traffic. Never ride against traffic.
- Use correct hand signals to indicate turning, and do so well in advance of turning.
- Ride defensively. To other road users you may be hard to see.
- Increase your visibility by following the tips in “Low-visibility conditions” on the next page.

## OFF-ROAD RIDING (No recommended)

Riding off road requires close attention and specific skills, and it presents variable conditions and hazards. Don't ride off road unless you have the appropriate skills. If you choose to ride off road, wear appropriate safety gear and do not ride alone in remote areas.

## HOT OR COLD CONDITIONS

Riding, parking, or storing your bike in excessively hot conditions can cause damage to the display and other components. Do not park or store your bike in direct sunlight for extended periods. For more information on safe and recommended temperature ranges for your battery.

## LOW-VISIBILITY CONDITIONS



**WARNING:** Riding at night or in other low-visibility conditions (dawn, dusk, fog, rain, mist, snow, etc.) makes it harder to see and avoid hazards and makes it harder for others to see and avoid you, which increases risk of accidents, serious injury, or death. Wet, slippery surfaces will compound your risk of injury or death. Avoid these conditions whenever possible. If you must ride in these conditions, following the guidelines below can reduce risk.

- Wear reflective and brightly coloured clothing.
- Slow down.
- Use familiar routes with street lighting if possible.
- Ensure tyre wall, pedal, and other reflectors are installed and unobstructed.
- Ensure headlight and taillight/brake light are functioning correctly and unobstructed. Use them.

## WET CONDITIONS

This electric bike is not meant for use in puddles, heavy rain, or streams. Never immerse or submerge this product in water or liquid as the electrical system may be damaged.



**WARNING:** Riding in wet conditions means slippery hands, feet, and riding surfaces, which greatly increases your risk of accidents, serious injury, or death. Low-visibility conditions (night, dusk, dawn, fog, mist, rain, snow, etc.) will compound your risk of injury or death. If you must ride in wet conditions, following the guidelines below can mitigate risk somewhat.

- Decrease riding speed to help you control the bike in slippery conditions.
- Brake earlier since it will take longer to slow down than in dry conditions.
- Take care to be more visible to others on the road, following the tips in “Low-visibility conditions” on the previous page.
- Remember that road hazards are more difficult to see when wet, so proceed with extra caution.

## EXTREME RIDING

There are no appropriate conditions for extreme riding. Although many articles, advertisements, and catalogues depict extreme riding, SLIDER strongly recommends against such inappropriate and dangerous use of its products.



**DANGER:** Extreme riding puts you at VERY HIGH RISK of serious injury or death. Extreme riding includes but is not limited to jumps, stunts, or any riding that exceeds your capabilities or the strength and integrity limitations of certain bike components and/or otherwise leads to dangerous situations. Never engage in extreme riding or any type of riding that exceeds your capabilities.

## Wear a helmet and appropriate safety gear

We strongly advise that you and any passenger you carry wear a properly fitting, certified bicycle safety helmet while riding your bike, which may be required by law in your area.

Wear appropriate safety gear including closed-toe shoes. If you are wearing loose pants, secure the bottom using appropriate leg clips or bands to prevent the fabric from flapping and getting caught in the chain or other moving parts. Never use items such as headphones or hoods that can compromise your hearing or field of vision. A local, certified, and reputable bike shop can help advise you on what gear is best for the weather and other riding conditions in your area.

Maximize your visibility with bright colours and reflective outerwear or vests. Never compromise your ability to be seen or heard by removing your bike's reflectors, blocking or removing the headlight or taillight, or removing the bell.



**DANGER:** Riding any bike without a helmet puts you at VERY HIGH RISK of serious head injury or death. Always wear a properly fitted helmet that covers the forehead. Many locations require specific safety devices. It is your responsibility to familiarize yourself and comply with the laws, rules, and regulations where you ride.

## We not recommended to replace any important parts of other brands

When users tampering the products with non-original parts, SLIDER won't be responsibility on any users' issues. Exclude such parts that are consuming parts such as: brake pads, tyres, brake wires and shifter wires, grip and saddles. All tampering consuming parts should be well installed and in same specs and quality, otherwise, SLIDER won't be responsible on the products that been tampered.

Important parts such as:

- |            |             |
|------------|-------------|
| -brakes    | -hub        |
| -fork      | -handle bar |
| -seat tube | -battery    |
| -motor     | -Derailleur |

## Limited warranty and other terms

Your bike's warranty and other binding legal terms (e.g., terms of purchase, etc.) are subject to change at any time. To view your terms of purchase, go to [www.slider.eu](http://www.slider.eu).

### SLIDER LIMITED WARRANTY TERMS

This Limited Warranty is in addition to your statutory rights.

All SLIDER ("RPB") E-Bikes (the "E-Bike") purchased in Europe, and their individual Covered Components (as defined herein), are protected against all manufacturing defects in material or workmanship with regard to the Covered Components for two years after the date of receipt of this ebike by the customer (the "Warranty Period"). This Limited Warranty is only applicable to E-Bike purchases in the Europe shall be subject to the applicable warranty terms offered by RPB in those jurisdictions) and in accordance with the following terms:

-Only the original owner of the E-Bike is covered by this Limited Warranty. The Warranty Period begins upon your receipt of the E-Bike and shall end immediately upon the earlier of the end of the Warranty Period or any sale or transfer of the E-Bike to another person, and under no circumstances shall the Warranty apply to any subsequent owner or other transferee of the E-Bike.

-The Limited Warranty is expressly limited to the replacement of any of the following components that come standard on your ebike model (not all parts listed come standard with all models), if those components are found to be defective: lithium ion battery (the "Battery"), frame, forks, stem, handlebar, headset, seat post, saddle, brakes, lights, bottom bracket, crank set, pedals, rims, wheel hub, freewheel, cassette, derailleur, shifter, chain tensioner, motor, throttle, twist power assist, controller, wiring harness, LCD display, LED display, UI display, remotes, kickstand, reflectors and hardware (each a "Covered Component").



# THIS LIMITED WARRANTY DOES NOT COVER

- Normal wear and tear of any Covered Component.
- Consumables or normal wear and tear parts (such as tyres, tubes, brake pads, cables and housing, grips, chain, spokes), unless defective when received.
- Any damage or defects to Covered Components resulting from failure to follow instructions in the E-Bike owner's manual, acts of God, accident, misuse, neglect, abuse, commercial use, alterations, modification, improper assembly, installation of parts or accessories not originally intended or compatible with the E-Bike as sold, operator error, water damage, extreme riding, stunt riding, or improper follow-up maintenance.
- For the avoidance of doubt, RPB will not be liable and/or responsible for any damage, failure or loss caused by any unauthorized service or use of unauthorized parts.
- The Battery is not warranted from damage resulting from power surges, use of an improper charger, improper maintenance or other such misuse, normal wear or water damage.
- Damage that occurs during shipping if the owner sets up their own shipping option or if the bike is shipped using a freight forwarder or similar service.
- Any products sold by RPB that is not an E-Bike.
- Shipping damage if such damage is not reported to RPB within 30 days from receipt of product.

DETERMINING WHETHER DAMAGE OR DEFECT TO AN E-BIKE OR COVERED COMPONENT IS PROTECTED BY THIS LIMITED WARRANTY SHALL BE IN SOLE DISCRETION OF RPB.

## CLAIMS PROCESS

RPB WILL NOT REPLACE ANY COVERED COMPONENT UNDER THIS LIMITED WARRANTY WITHOUT FIRST SEEING PHOTOS OR VIDEO OF THE DAMAGED COVERED COMPONENT.

Before making a warranty claim, we suggest that you contact our Product Support team at [www.slider.eu](http://www.slider.eu) as there may be a simple fix for your problem.

Subject to your rights to cancel set out in the Consumer Purchase Terms and Conditions, in order to exercise your right to receive a replacement for a Covered Component under this Limited Warranty, you must:

-Contact the RPB Product Support team by email at [contact@slider.eu](mailto:contact@slider.eu) or by phone at +35-9897494937. The Product Support team will initially work with you on the problem with your E-Bike to identify potential simple fixes.

-In the event that the Product Support team determines that a Covered Component must be replaced, they will provide you with a set of instructions for returning the defective Covered Component and receiving the replacement.

-After you receive the replacement Covered Component, the Product Support team will also provide assistance in determining how to replace or install the new Covered Component into your E-Bike.

-You will be responsible for shipping costs associated with returning a Covered Component, unless RPB agrees in writing to pay for such shipping costs. Replacement Covered Components under this Limited Warranty shall only be shipped to the address of the original purchaser.

All claims to this warranty must be made through SLIDER within 1 years of initial purchase. Warranty claims may be submitted to [www.slider.eu](http://www.slider.eu).

THIS LIMITED WARRANTY GIVES YOU SPECIFIC LEGAL RIGHTS AND YOU MAY ALSO HAVE OTHER STATUTORY RIGHTS IN RELATION TO THE PRODUCTS AND THOSE RIGHTS ARE NOT AFFECTED BY THIS LIMITED WARRANTY.

Contact us :

Phone : +35-9897494937

Website : [www.slider.eu](http://www.slider.eu)

Location : Kuklensko Shose 21 B, Bulgaria



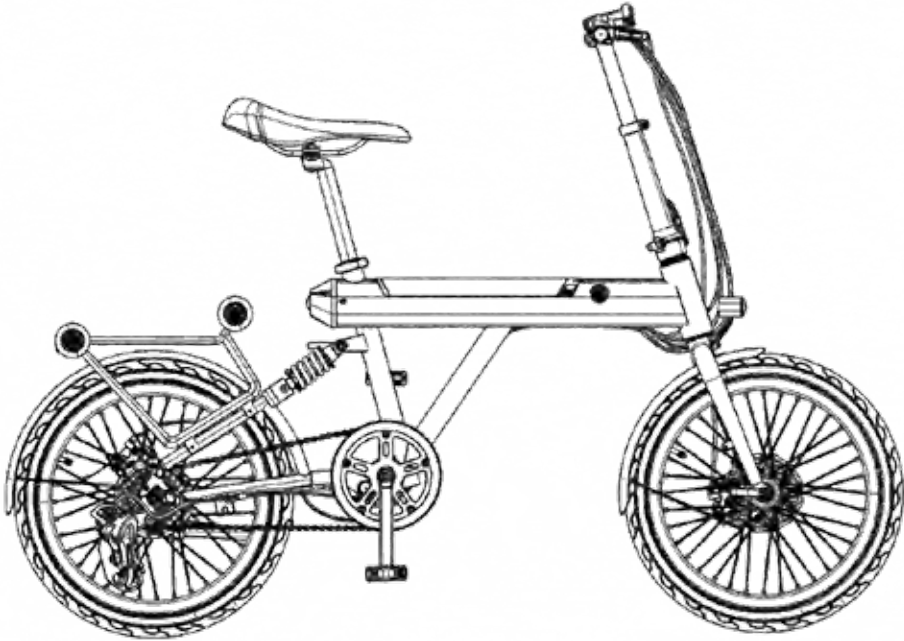

Start Your New Journey with Metro E3

All purpose arrives.

slider.eu

S L I D E R